



Installation Manual

1968-1970 MOPAR B-BODY FACTORY AIR

DOCUMENT #1-3066FA VERSION A

©2023 ClassicAutoAir / 5.24





Congratulations...

You have just purchased the highest quality, best performing A/C system ever designed for your Mopar.

To obtain the high level of performance and dependability our systems are known for, please pay close attention to the following instructions. Our installation steps and procedures are derived from a long history of research and development and the combined experience achieved thru thousands of successful installations (and feedback from customers like you). Please remember that our #1 goal is that you'll have a successful installation and a system that performs at a very high level for many years to come.

Before starting, read the instructions carefully, from beginning to end, and follow the proper sequence. On the next page you'll find a safety and general checklist that you should read before starting your installation.

Again, thank you from our entire staff.



Check List, Pre-Installation:

- Before beginning the installation check the shipping box for the correct components. YOUR BOXED UNIT INCLUDES A LIST OF MAJOR COMPONENTS AND A LIST OF BAGGED PARTS. We have a 5 stage check process to make sure you have everything you'll need.
- If your vehicle has been or is being modified, some procedures will need to be adjusted to fit your particular application.**
- A basic cleaning of the engine compartment and interior before beginning will make things go more smoothly.
- Check condition of engine mounts. Excessive engine movement can damage hoses to A/C and/or heater.
- Before starting, check vehicle interior electrical functions (interior lights, radio, horn, etc). Make a note of anything that does not work as it's supposed to. During the installation you might find the opportunity to repair or upgrade non-working or out of date components. When you're ready to start the installation, **DISCONNECT THE BATTERY FIRST.**
- Drain the radiator. Retain the coolant and reuse, or dispose of properly.
- SAFETY FIRST: Wear eye protection while drilling/cutting, deburr sharp edges, and never get in a hurry or force a part.
- Tools: Your installation only requires the basic tools everyone has in their garage, nothing exotic or specific to A/C or Heat equipment.

Procedures, During Installation:

- Fittings: Use one or two drops of mineral oil (supplied with your kit) on ALL rubber o-rings, threads and where o-rings seat in fittings. Do not use thread tape or sealants.
- Measure twice (or more), cut once
- Should you have any technical questions, or feel you have defective components (or missing items), call us immediately, we will be glad to assist you.**

YOU CAN NOW BEGIN THE INSTALLATION...

A Basic Overview of Automotive A/C....

- 1 **Evaporator with Blower Fan** In order to remove the heat from the air in the vehicle, the A/C evaporator allows the refrigerant to absorb the heat from the air passing over it. The blower fan moves cool air out into the car interior.
- 2 **Compressor** The compressor pumps and circulates the refrigerant through the system.
- 3 **Condenser** The condenser is a heat exchanger mounted at the front of the vehicle. Heat drawn out of the interior of the car is expelled here.
- 4 **Receiver/Drier** The drier not only dries refrigerant, it also filters the refrigerant and stores it under certain operating conditions.
- 5 **High Pressure Switch** A pressure switch is used to shut down the system if high or low pressure is detected, basically it acts as a safety switch.

The air conditioning system in your vehicle is comprised of a compressor, condenser, expansion valve, receiver/drier, and evaporator. Refrigerant (also known as Freon) is compressed in the compressor. In the condenser, gas is cooled to a liquid state and travels to the expansion valve. As the liquid refrigerant goes through the expansion valve it rapidly cools in the evaporator. A fan blows over the evaporator and cools the air that blows out your vents.

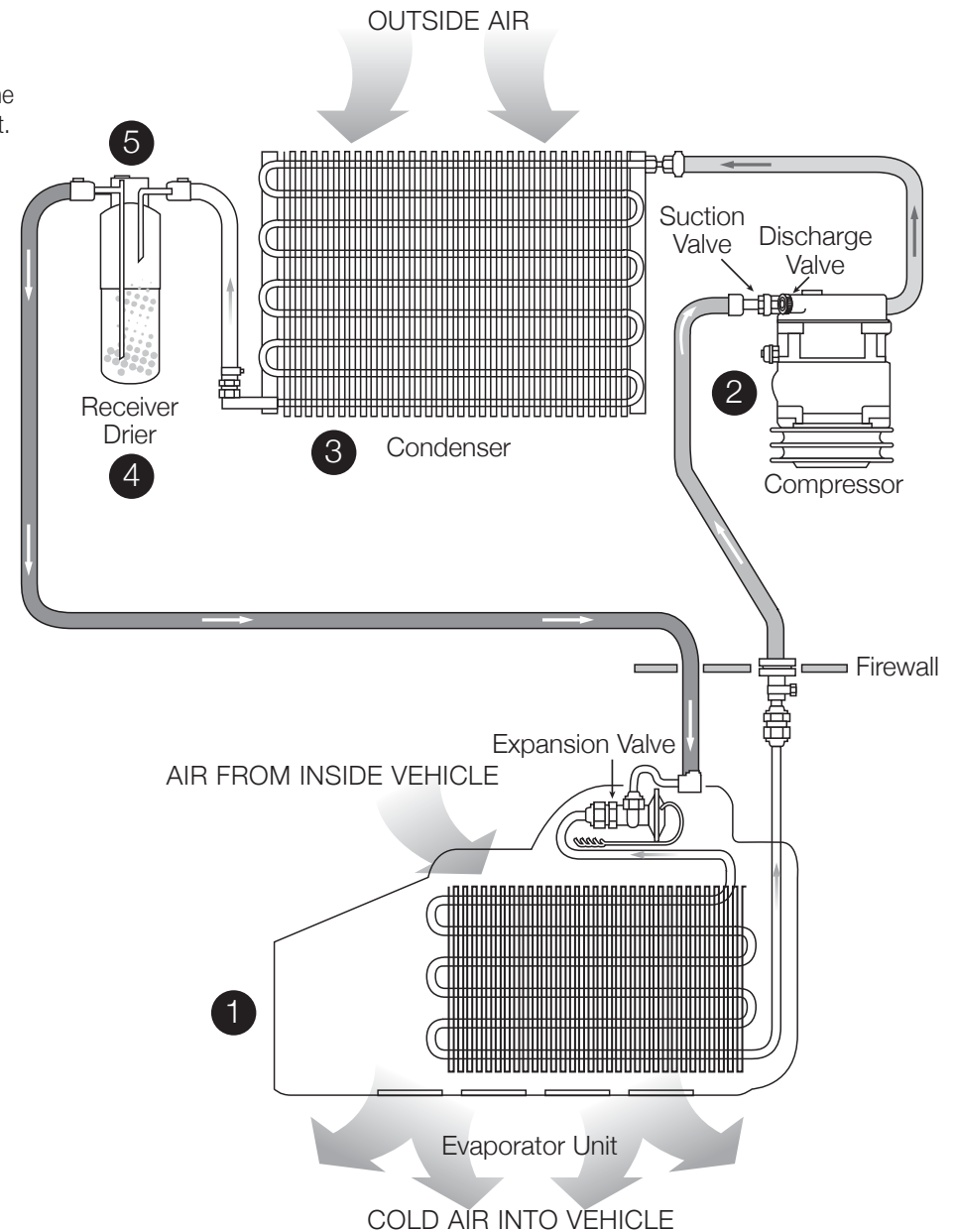

Take a minute to familiarize yourself with the evaporator unit:

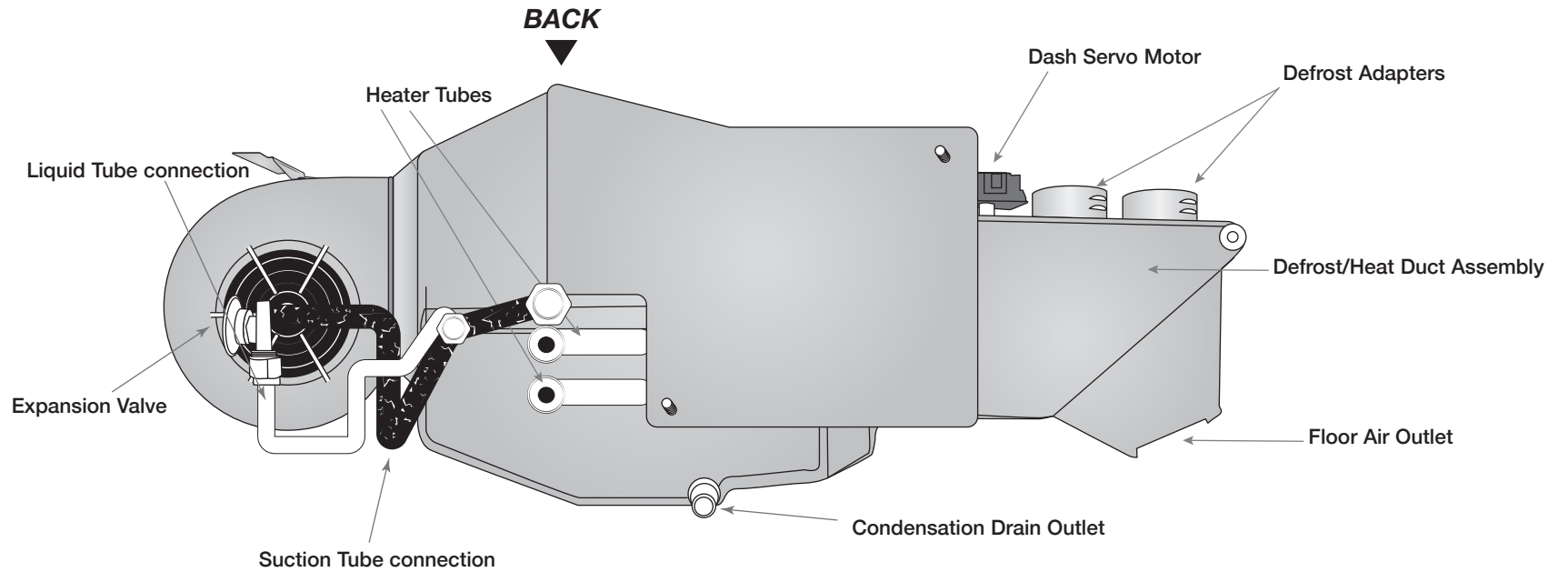
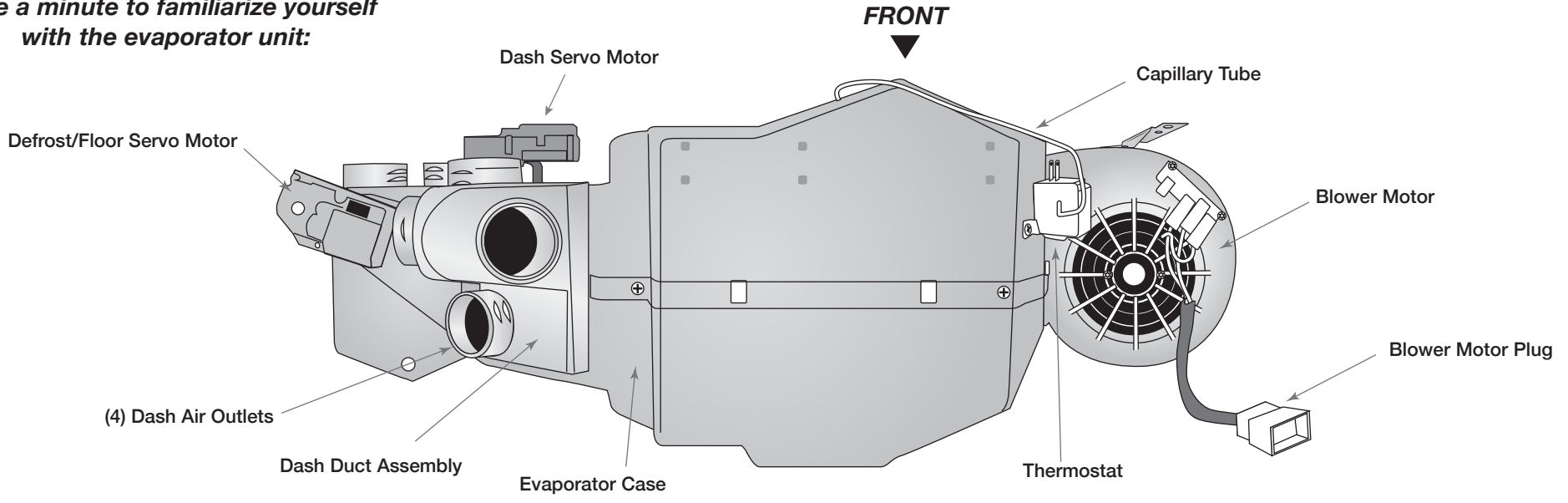



Control & Operating Instructions

Your new **Smart Series A/C** system offers complete comfort capabilities in virtually every driving condition. This includes Hot and Cold temperature control in all of the modes. This system also provides the ability to blend the air between Dash, Floor, and Defrost modes simultaneously. To illustrate the various ways you can adjust the airflow direction and temperature - we've provided these handy illustrations and chart to show exactly how you can adjust your **Smart Series A/C** for maximum comfort...

The FAN switch works like the OEM switch, the lever pulled fully toward you is OFF (all power to the system is OFF in this position)

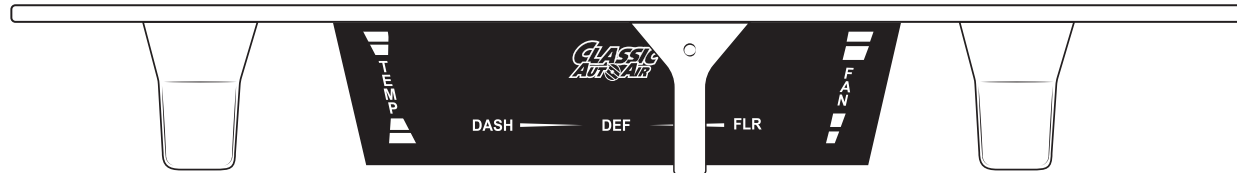

NOTE: When the TEMP lever is pulled fully toward you (the coldest setting) position, the compressor is ON, no matter what position the MODE lever is in (think of it as a compressor-override function)

TEMP	PULLED FORWARD										PUSHED BACK
	COLD										HOT
VALVE POSITION	CLOSED - 0%	OPEN - 10%	OPEN - 20%	OPEN - 30%	OPEN - 40%	OPEN - 50%	OPEN - 60%	OPEN - 70%	OPEN - 80%	OPEN - 90%	OPEN - 100%
COMPRESSOR	ON	ON	ON	ON	ON	ON	ON	ON	ON	ON	OFF

MODE	DASH					DEF					FLOOR
	Dash A/C 100%	Dash A/C 80% Defrost 20%	Dash A/C 60% Defrost 40%	Dash A/C 40% Defrost 60%	Dash A/C 20% Defrost 80%	Defrost 100%	Defrost 80% Floor 20%	Defrost 60% Floor 40%	Defrost 40% Floor 60%	Defrost 20% Floor 80%	Floor 100%
COMPRESSOR	ON	ON	ON	ON	ON	ON	ON	ON	ON	ON	ON

FAN	PULLED FORWARD				PUSHED BACK
	OFF	LOW	MED	HIGH	
BLOWER	OFF	LOW	MED	HIGH	

There are 11 levels of adjustment within the range of the DASH - DEF - FLR lever

OPERATION

1

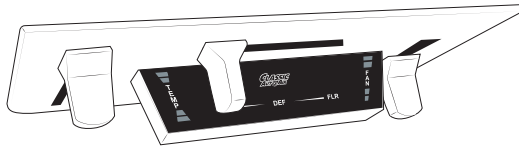

Move FAN knob to HIGH
Move MODE knob to DASH
Move TEMP knob to COLD



AIR OUT OF DASH VENTS

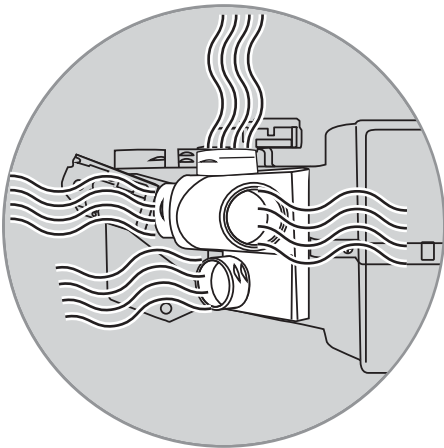

2

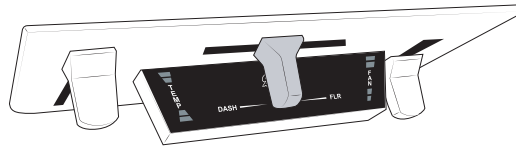

Move MODE knob to DEF



AIR OUT OF DEFROST VENTS

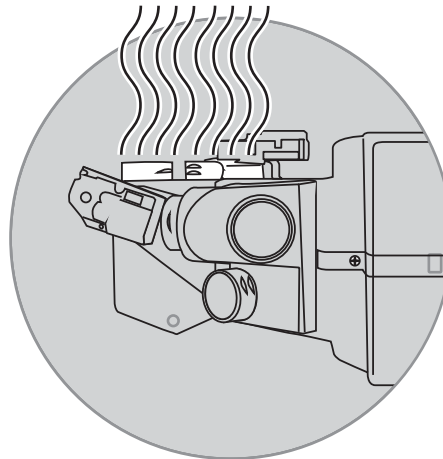

3

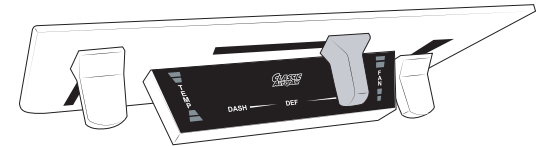

Move MODE knob to FLOOR



AIR OUT OF FLOOR VENTS

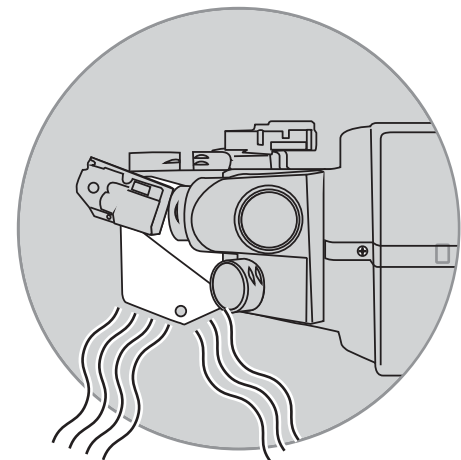

OPERATION

4

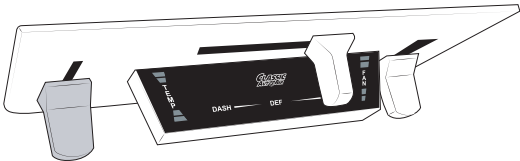

Move TEMP knob to HOT

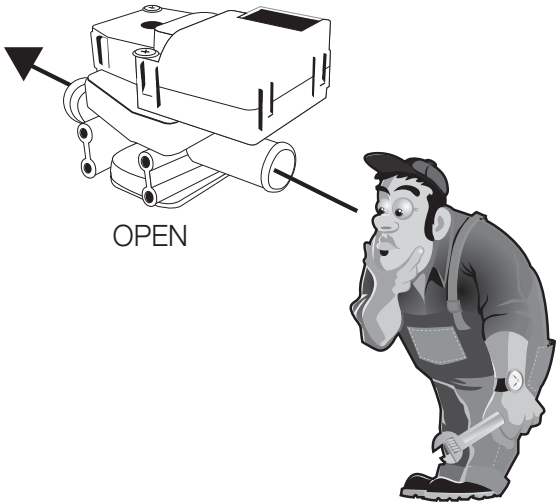

OPEN

You will be able to see through water valve passage

5

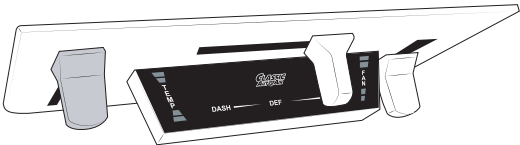

Move TEMP knob to COLD

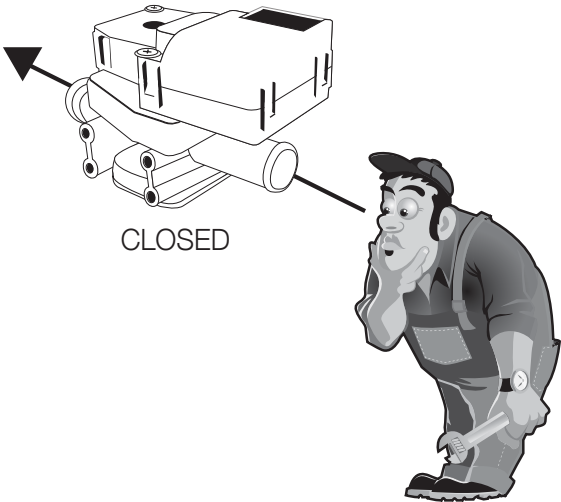

CLOSED

You will NOT be able to see through water valve passage

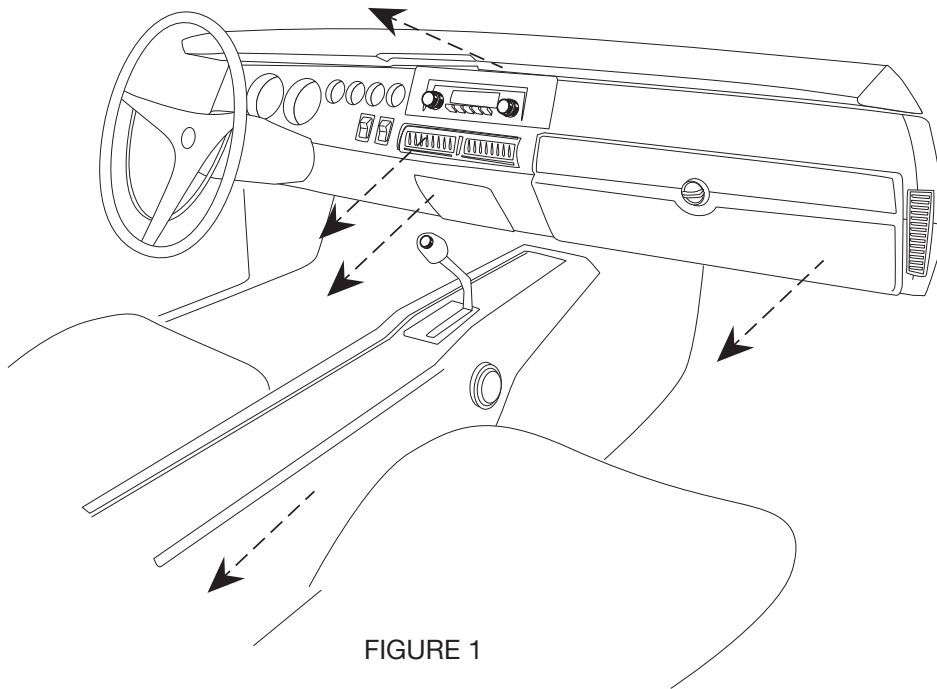

FIGURE 1

Remove Glove box, Glove box door, Ashtray, and Radio, and OEM A/C controls (we provide our new D.E.R. controls). and set them aside for reinstall later (see figure 1).

Note: If vehicle is equipped with a console, remove entire console and set aside.



When retaining parts it's a good idea to store parts in a zip lock bag, labeled with info where the parts came from and what size/type of tool is needed to reinstall. Cleaning the parts before you need to reinstall them is a good idea too.

Disconnect the electrical harness from the OEM assembly. Remove front support brace from the OEM unit (see figure 2). Retain the hardware (we will be providing a new support brace).

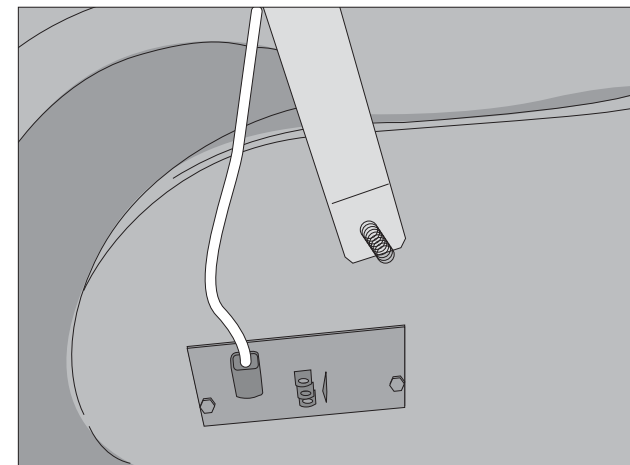

FIGURE 2

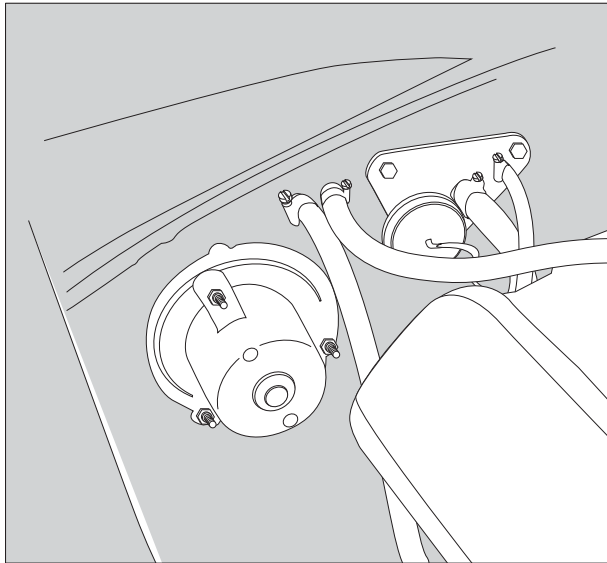

FIGURE 3

DRAIN COOLANT FROM RADIATOR. Store safely to reuse or recycle accordingly. Cut heater hose approximately 1" from firewall (see figure 3). Also, to prevent forgetting to refill the coolant when the installation is completed, do not put the cap back into place - instead put the cap to the side and cover radiator hole with a clean rag or something similar.

Remove all the factory duct hoses and discard. Unhook the cable to the OEM heater valve and push the tout thru the firewall. Remove all 5 nuts that hold OEM A/C unit to firewall (see figure 4). At this point the OEM A/C unit should be free and you can remove from the vehicle. Nothing on the OEM unit will be reused on this installation.

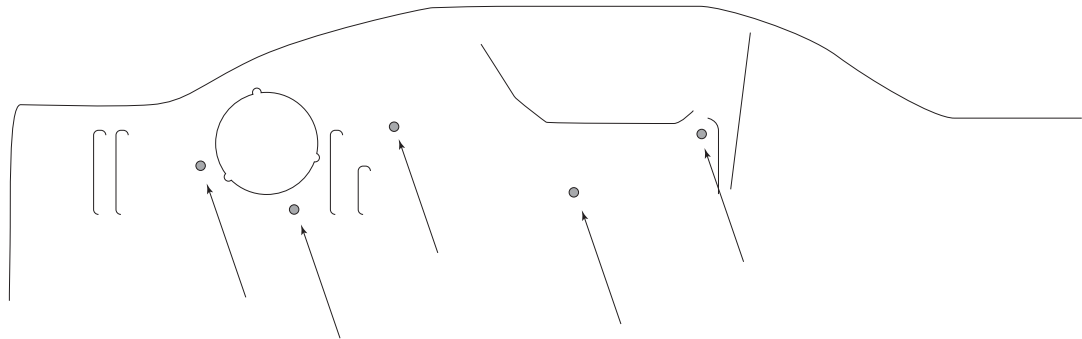
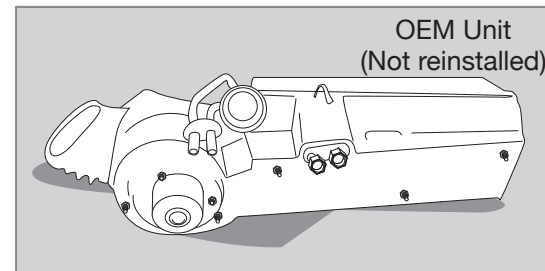
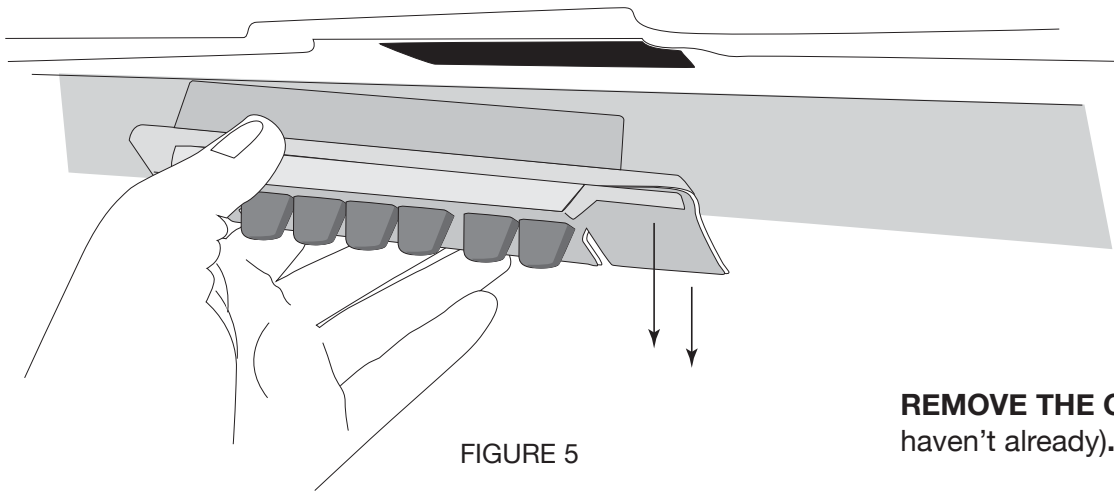

FIGURE 4

Remove all 5 OEM nuts





REMOVE THE OEM CONTROL HEAD FROM THE DASH (if you haven't already).

1) There are four screws that hold the OEM control unit in the dash. Remove the screws and set the assembly aside (see figure 5).

THESE ARE THE PARTS YOU WILL FIND IN THE CONTROL BOX

(varies based on your choice of using your factory controls or using our new D.E.R. Controller)

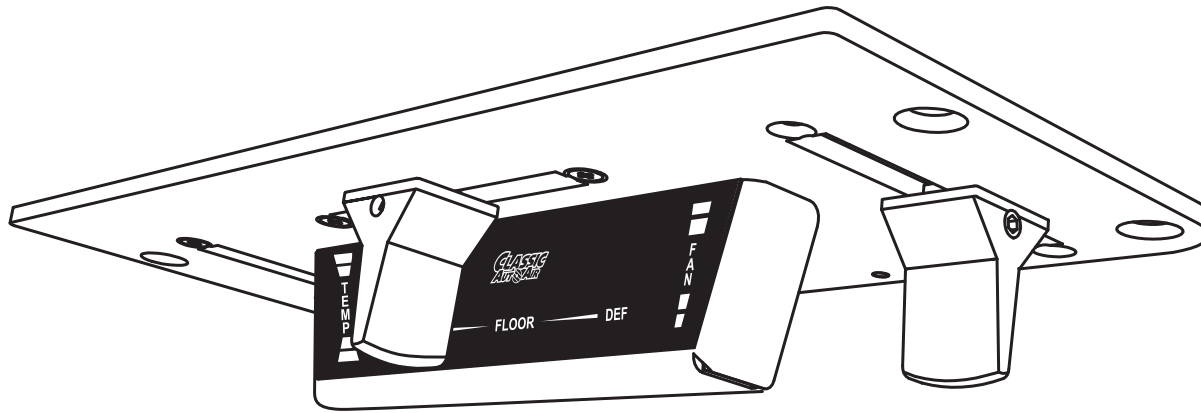

D.E.R. Controller
PN# 16-4066

Mount D.E.R. into dash using OEM hardware (see figure 6).

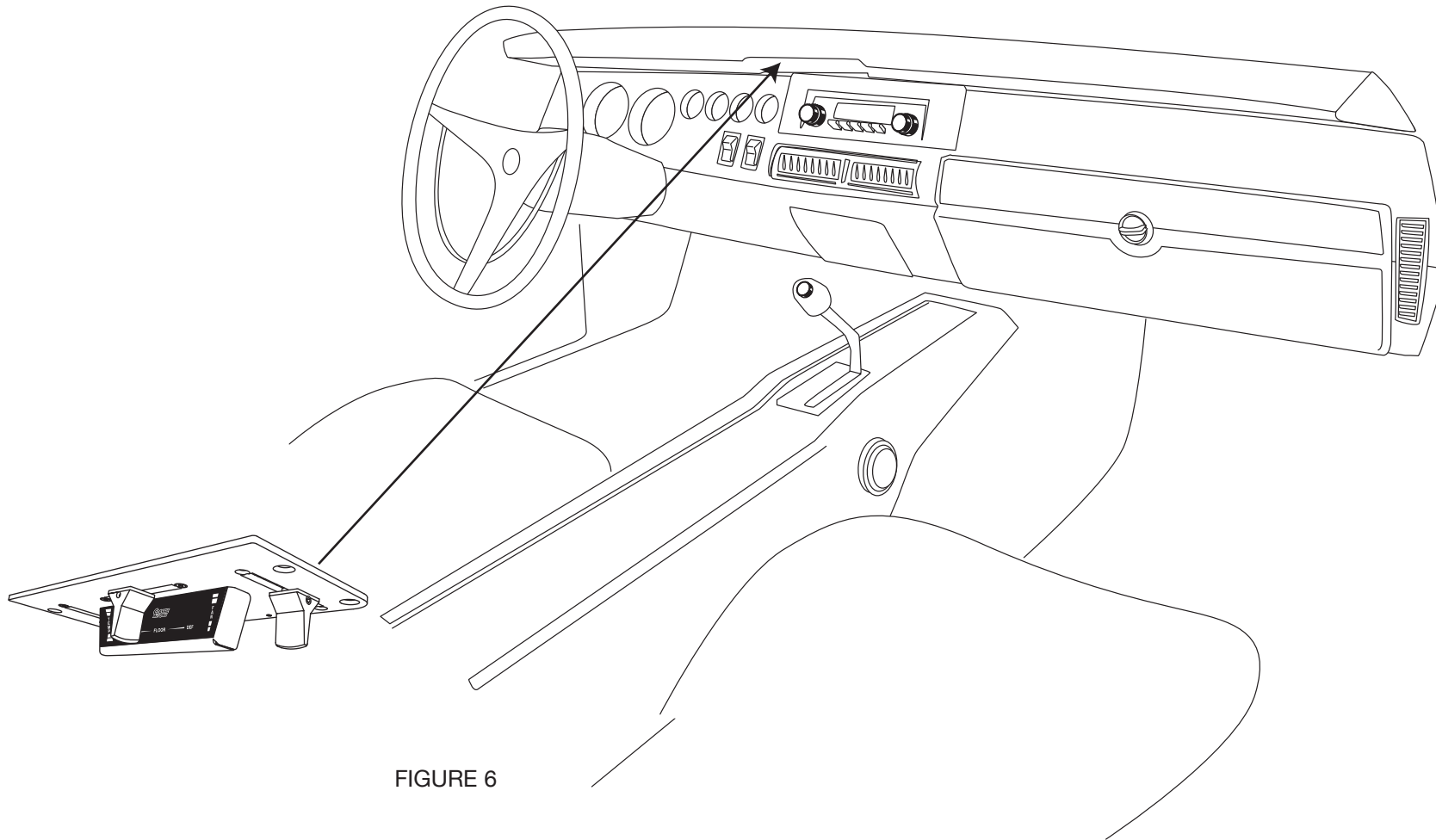
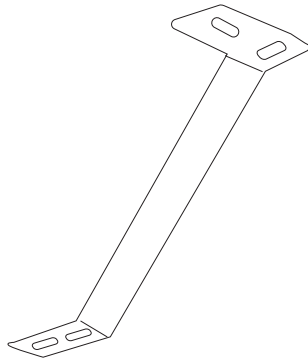

FIGURE 6

THESE ARE THE PARTS YOU WILL FIND IN BAG KIT B

You will use all of these parts and hardware during the next series of installation steps.



Evap Support Bracket
PN# 066-21R1

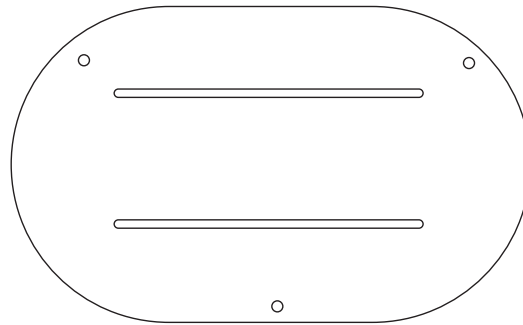

Fresh Air Inlet Block Off
PN# 10-1066-2

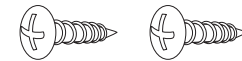

Two #10 - x 5/8" Phillips Screws

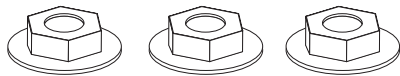

Three #10 - 10 x 5/8" Flange Nuts
PN#25CNFLZ/S

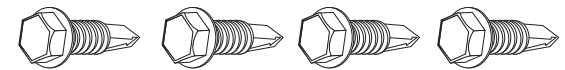

Four #10 - 16 x 3/4" Tek Screws

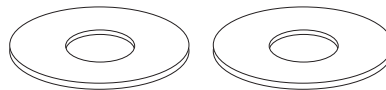

Two Fender Washers
PN #0113-3

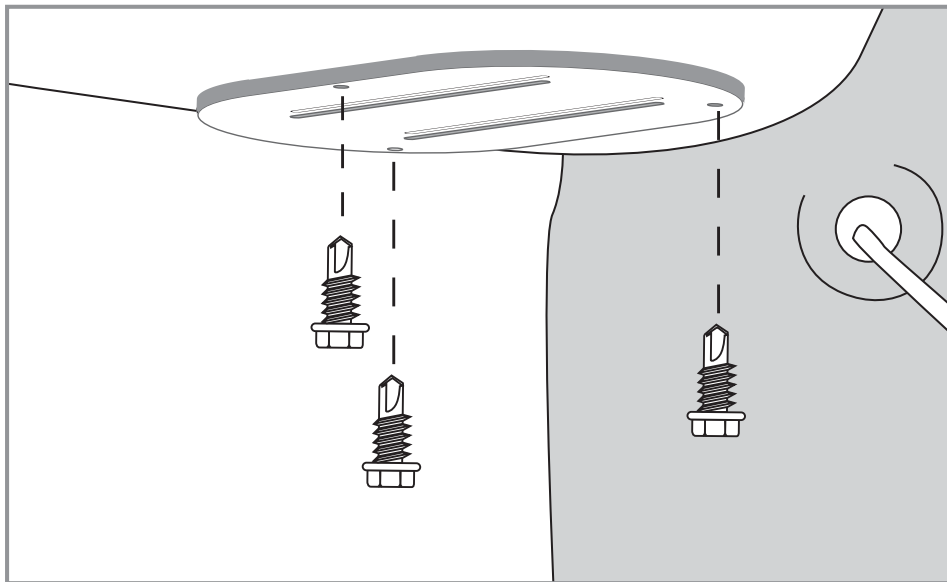

FIGURE 7

Locate the fresh Air inlet block off. Install over hole in inlet cowl as shown. Attach with three #10 - 16 x 3/4" Tek Screws (see figure 7).

Remove evaporator unit from box and place on a clean work bench.

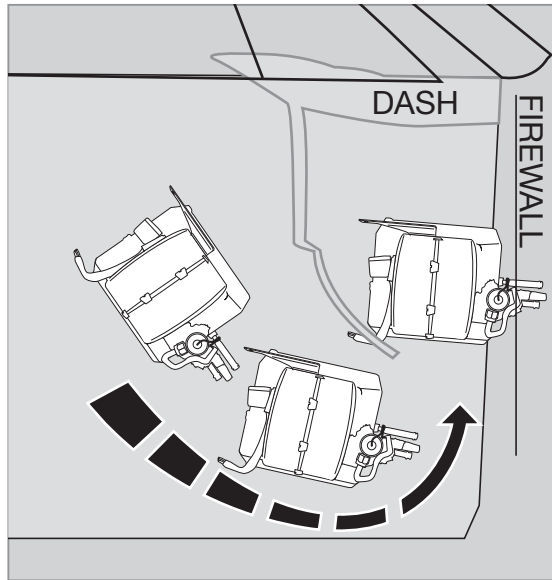

FIGURE 8

NOTE: Two people are needed for this step for easy installation.

Installing the complete evaporator unit under the dash will go much easier with the help of a friend. One person can take the unit within the car and “roll” up and under the dash while the other person can be ready at the firewall area with one or more of the included washers and flange nuts (the OEM hole are over sized and will require both a washer and flange nut for each). On back side of the evaporator is a mounting bracket with two studs. These studs will protrude thru the OEM holes (see figure 8).

Next, attach the bracket located on the blower motor to the underside of the cowling with a #10 - 16 x 3/4" Tek-screw (as shown in figure 9).

Now the unit will be easy to level and secure. Leveling the unit is very important to insure proper drainage of condensation (see below).

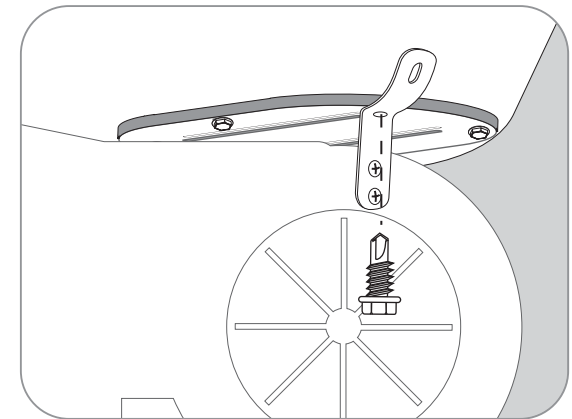
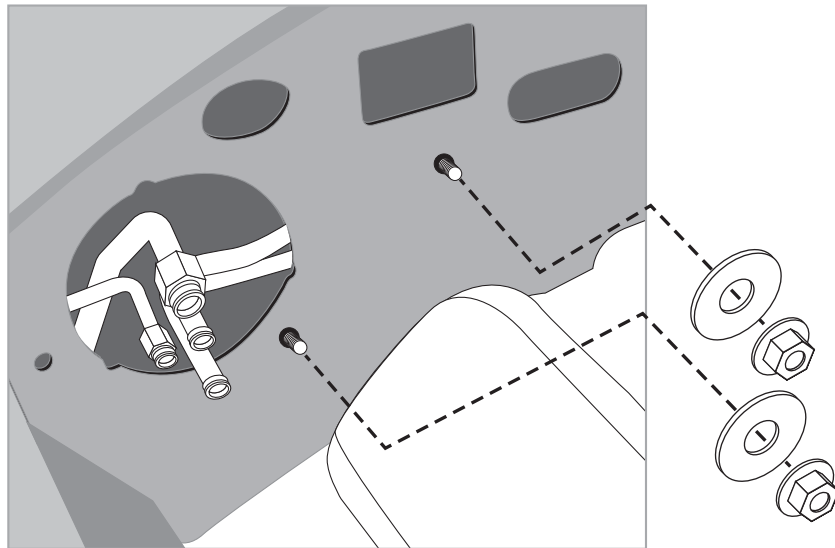
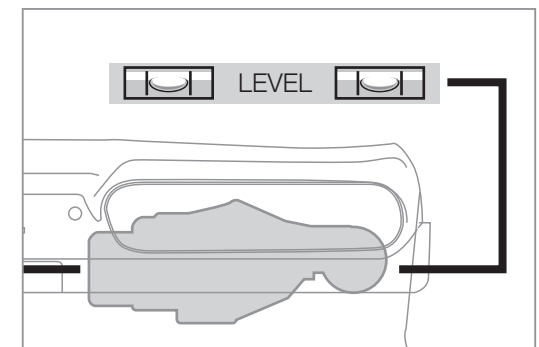

FIGURE 9



Be sure to align the evaporator unit level with the bottom of instrument panel (assuming the vehicle is sitting level) as shown, but with a small degree of tilt toward the back to allow proper drain of condensation.



We've included a new under dash evaporator brace to replace the OEM one. Our new brace has a different bend and is an important replacement. Mount the brace to the new evaporator as shown below, and use an included flange nut to secure (there is a OEM stud that you will use to secure the top of the bracket, see figure 10).

IMPORTANT NOTE: On the side of the main unit you will see several holes for mounting holes... **ONLY USE THE ONES ON THE FAR LEFT FOR THIS BRACKET!** Do not tap into the other holes for any reason. Also, use a screwdriver and hand-power and do not over-tighten so you don't strip the holes (see figure 10).

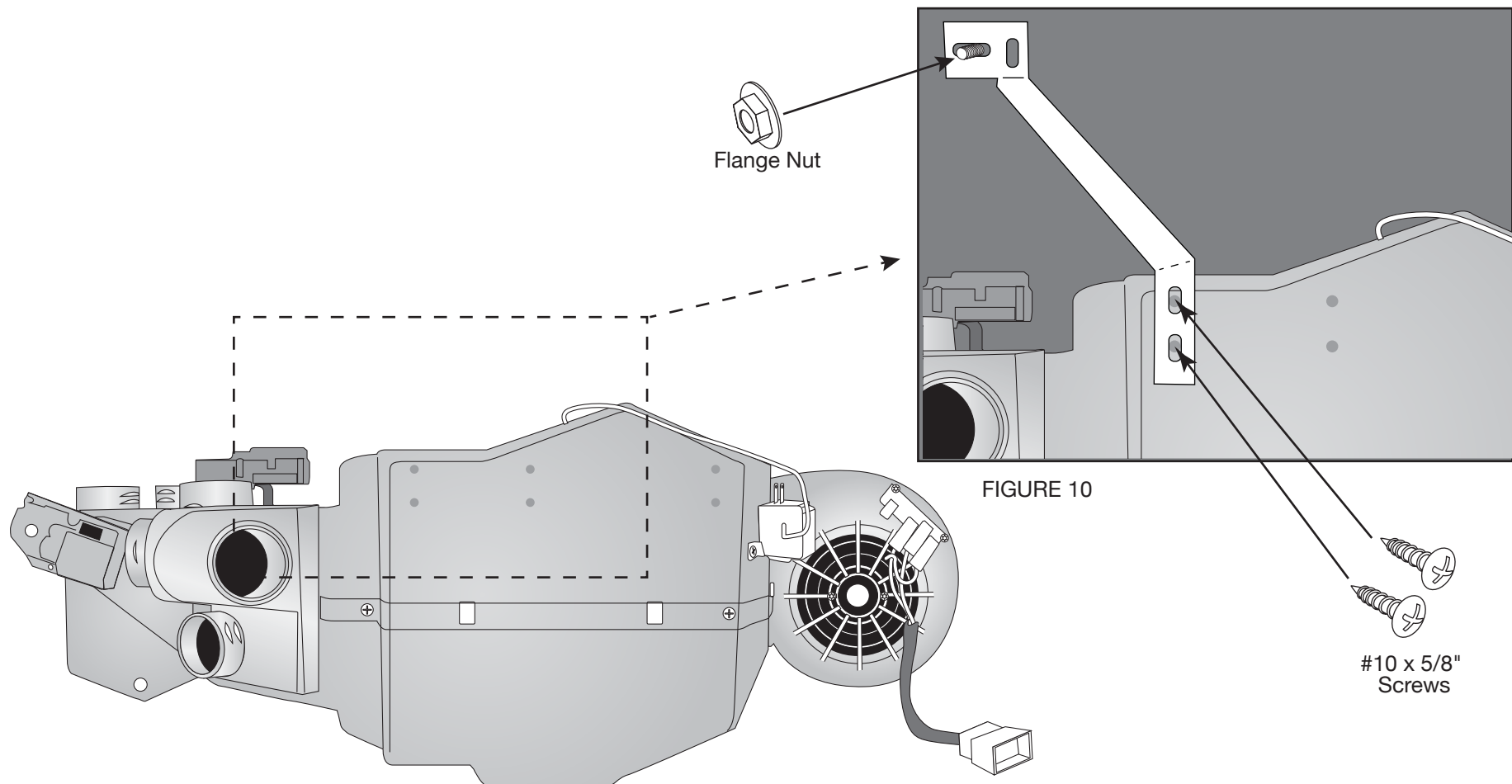

THESE ARE THE PARTS YOU WILL FIND IN BAG KIT C

You will use all of these parts and hardware during the next series of installation steps.

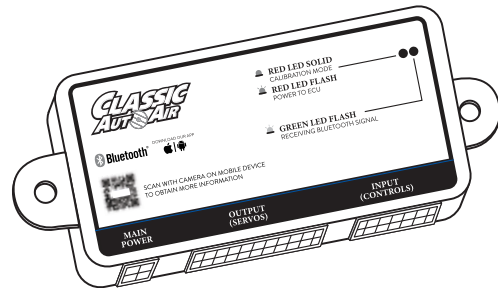

ECU
16-2500

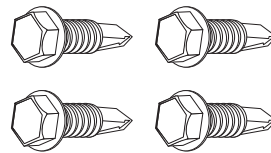

Four #10 - 16 x 3/4" Tek Screws

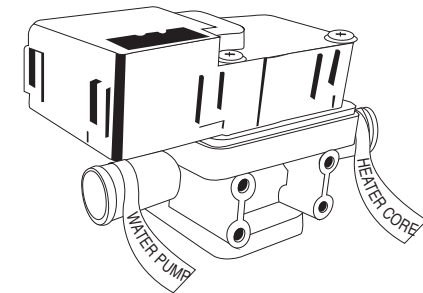

Electronic Water Control Valve
PN# 16-1023

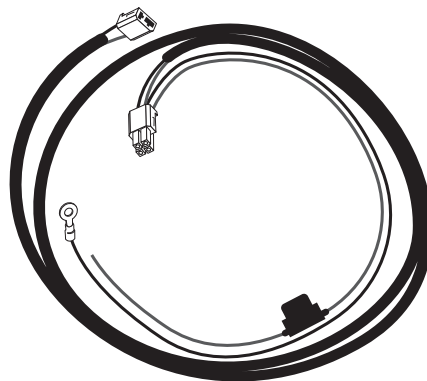

HARNESS POWER SUPPLY
0125-5



Relay
30-13373

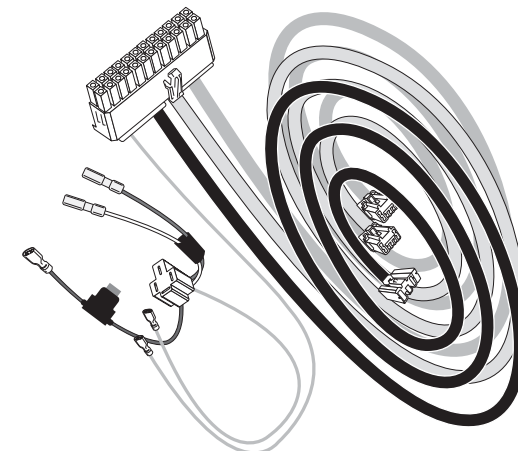

HARNESS
0125-6A

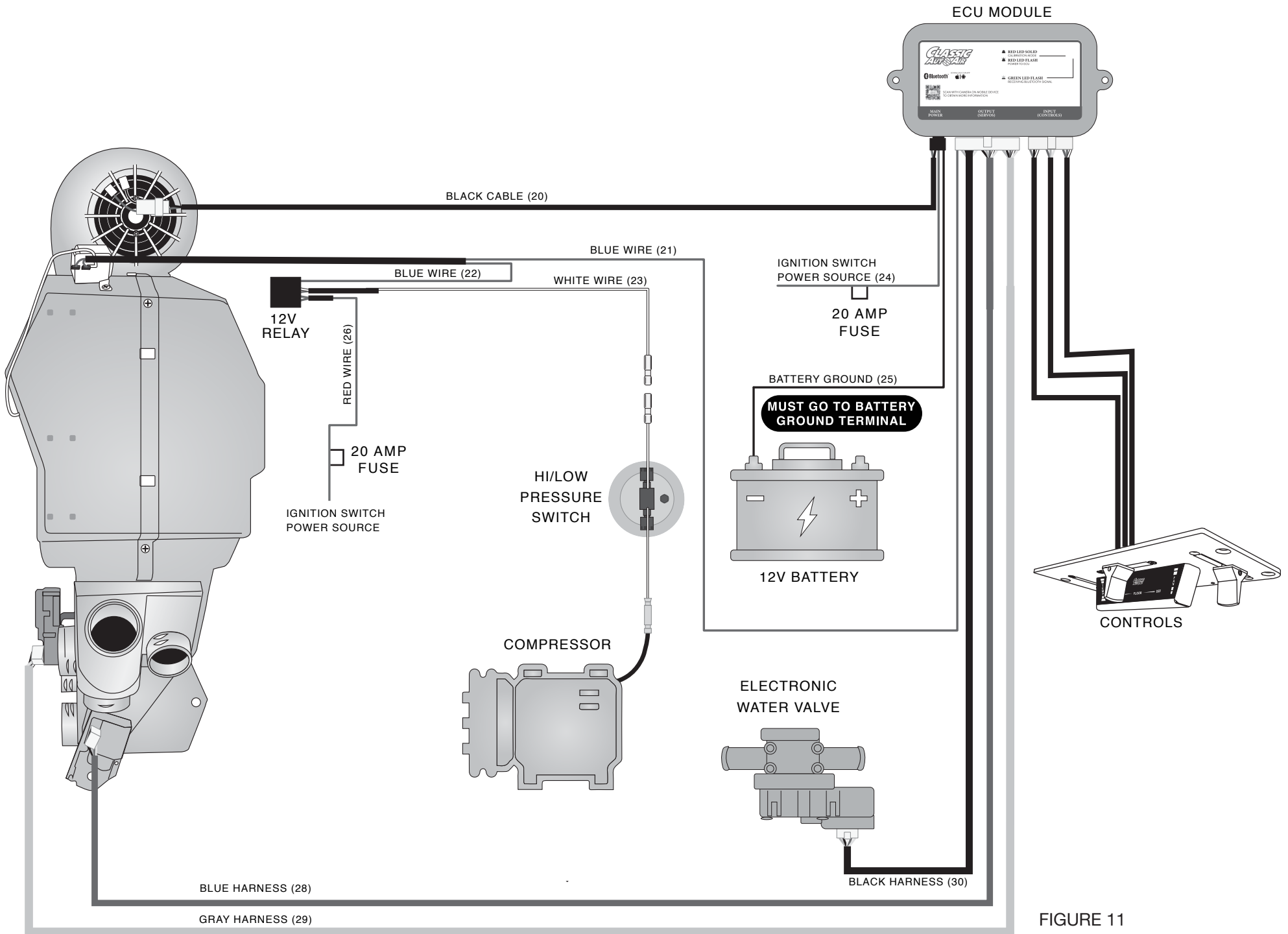

FIGURE 11

THESE ARE THE PARTS YOU WILL FIND IN BAG KIT D

You will use all of these parts and hardware during the next series of installation steps.



90 Degree Elbow

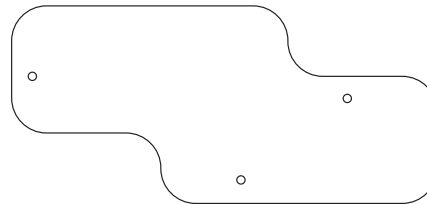

Firewall Block Off Plate
PN #10-2066FA-2

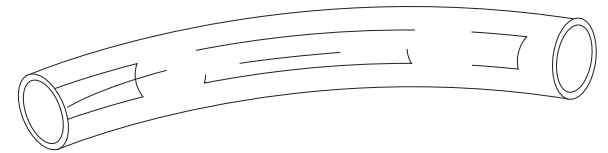

Clear Plastic Drain Tube

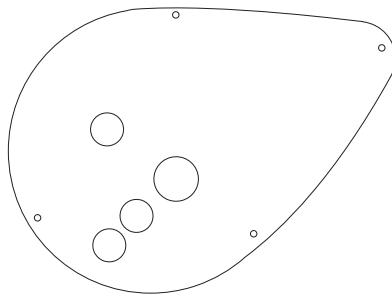

Firewall Block Off
PN# 10-2066FA-1

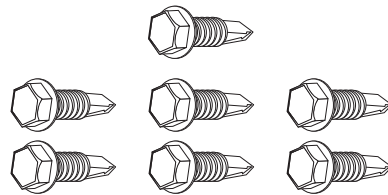

Seven #10 - 16 x 3/4" Tek Screws

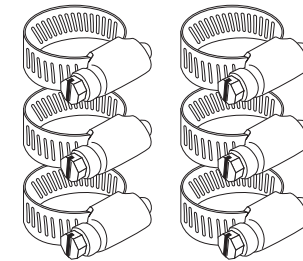

Six Worm Gear Clamps



Four Cap Plugs

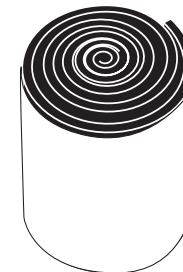

Refrigerant Tape

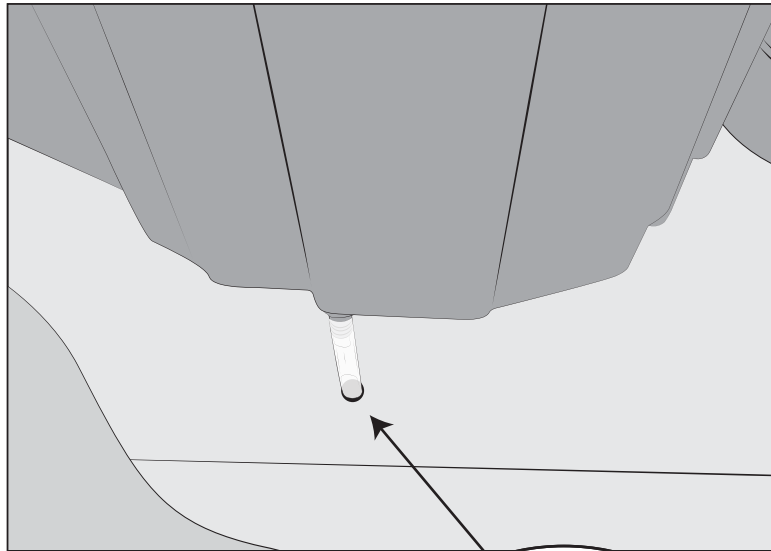

Attach drain tube as shown (see figure 12).

All condensation will now drain out into the engine bay.

FIGURE 12

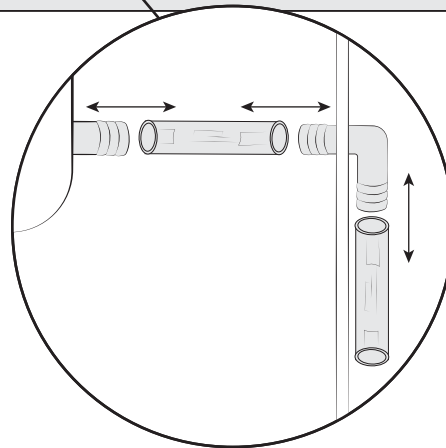

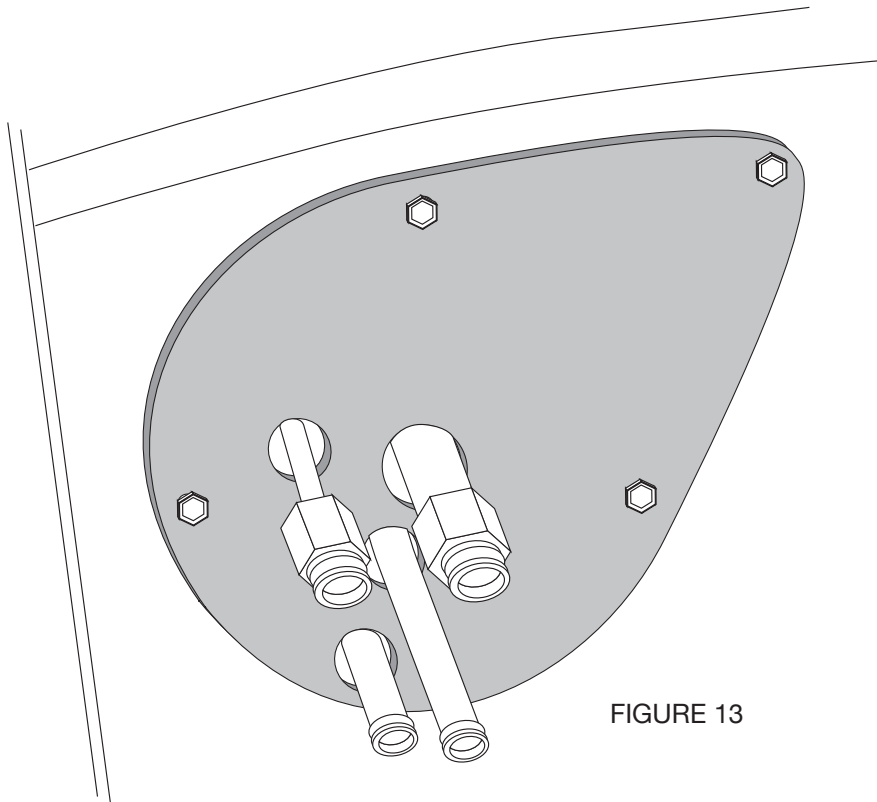

FIGURE 13

In **Bag Kit D** you'll find the firewall block off. Install this over the hose connections coming thru the firewall within the engine compartment. Attach with four #10 - 16 x 3/4" Tek screws (see figure 13).

IMPORTANT NOTICE: PROPER INSTALLATION OF WATER VALVE

Your water valve MUST be installed per these instructions!... (If not, your system will not work properly.

The **lower** heater tube connection on firewall will be routed to the water connection on intake manifold using 5/8" dia. heater hose with the supplied worm gear clamp.

The **upper** heater tube connection on the firewall will be routed to the water valve connection labeled **heater core**, using a 6" piece of 5/8" heater hose attached with supplied worm gear clamp.

Connect the remaining outlet on water valve labeled **water pump** to the water pump using 5/8" dia. heater hose with the supplied worm gear clamp (see figure 14).

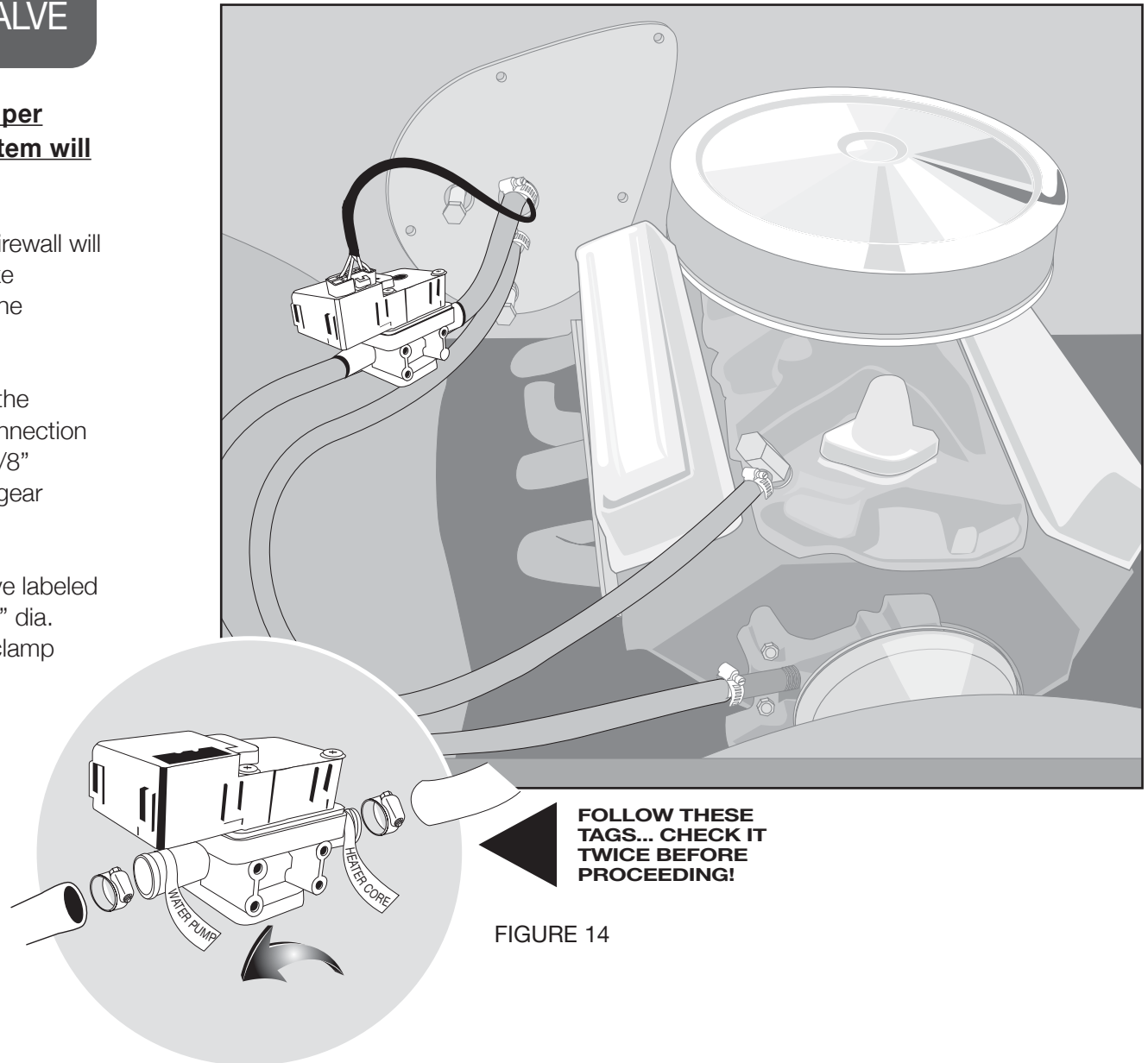

FIGURE 14

We've also included an additional block off plate to cover the OEM hole for the water valve and heater tubes. Use the remaining Tek-screws to secure the new plate (see figure 15).

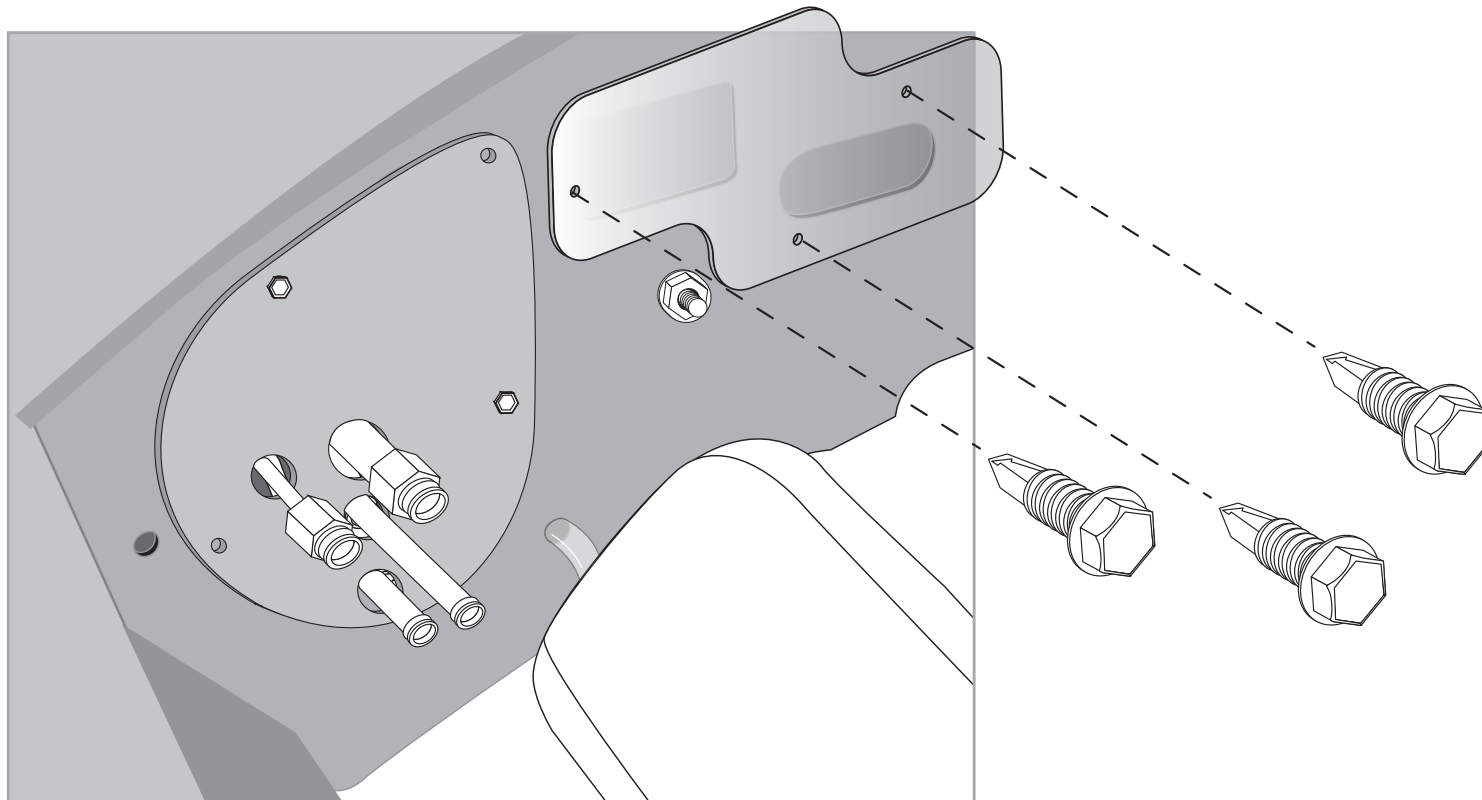
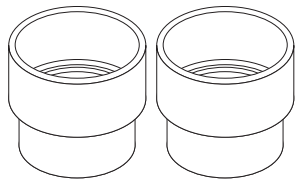

FIGURE 15

THESE ARE THE PARTS YOU WILL FIND IN BAG KITS E, F, and G

You will use all of these parts and hardware during the next series of installation steps.

Bag E



Two Defrost Duct Adapters
PN #2-2066FA-1

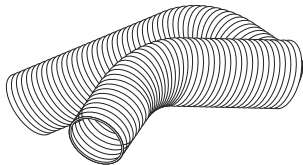

Two Duct Hoses, 2" I.D.

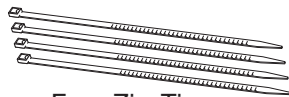

Four Zip-Ties

Bag F

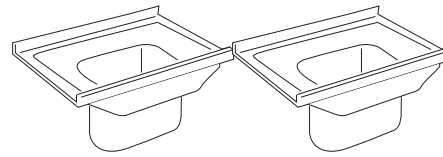

Two Duct Adapters
PN# 2-2066FA-2

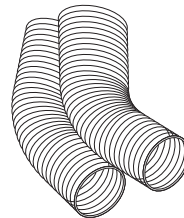

Two Duct Hoses, 2" I.D.

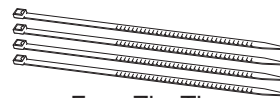

Four Zip-Ties

Bag G

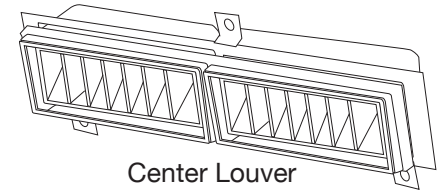

Center Louver
PN# 2-2066FA-3

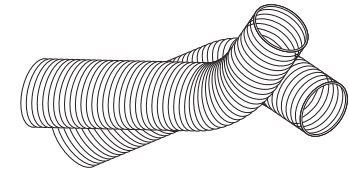

Two Duct Hoses, 2" I.D.

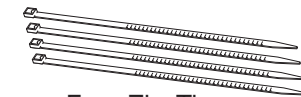

Four Zip-Ties

Illustrations NOT shown actual size

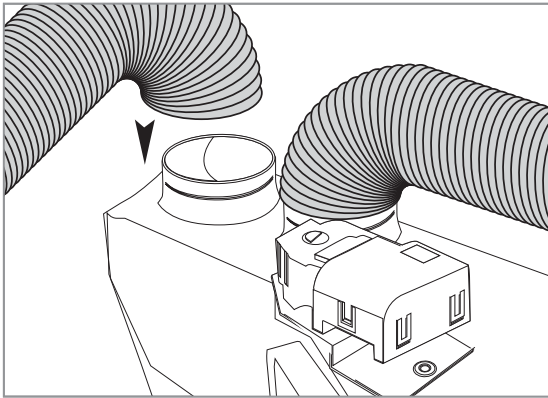
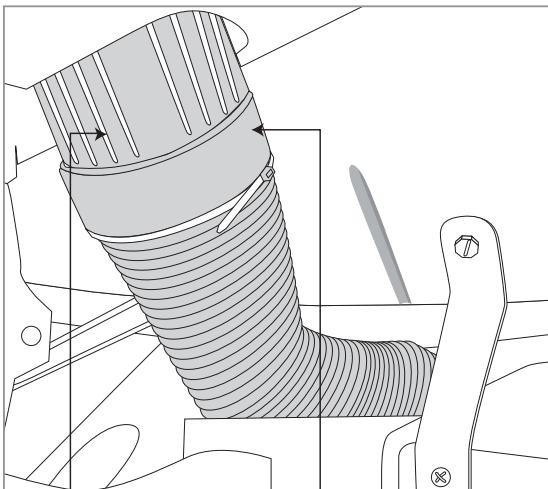

FIGURE 16

Bag Kit E: The following steps are for left and right Defrost Diffusers: Locate and route the duct hoses from the defrost/heat duct assembly (see figure 16) upward toward the defrost adapter diffusers.

Next locate and install defrost adapter diffusers from the top of the dash and secure with s-clips supplied. Attach flex hose to the defrost diffuser adapters using zip-ties. Push adapters onto diffusers from below. The other end of the duct hose is installed over the defrost/heat duct assembly outlets on main unit (see figure 17).



Defrost Adapter Diffuser

Defrost Adapter Reducer

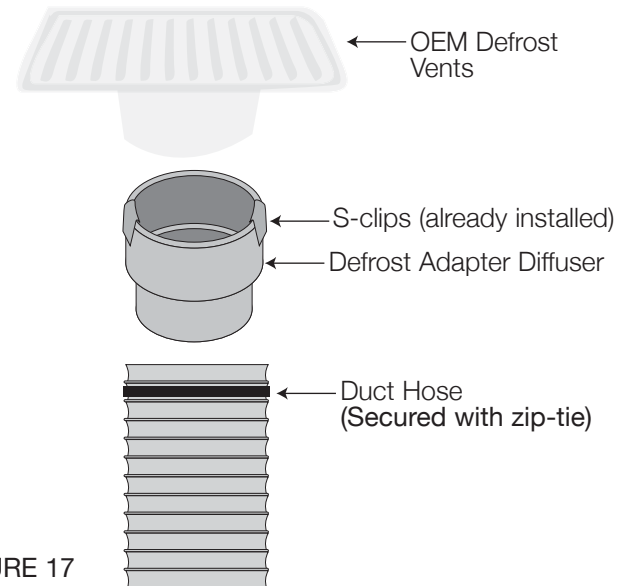

FIGURE 17

Bag Kit F: We've included two left and right (driver and passenger) side vent adapters. These come pre-installed with s-clip that will allow you to simple press them onto the back of the OEM vents. Next you can attach duct hose to each and route to the diffuser (as shown in figure 18).

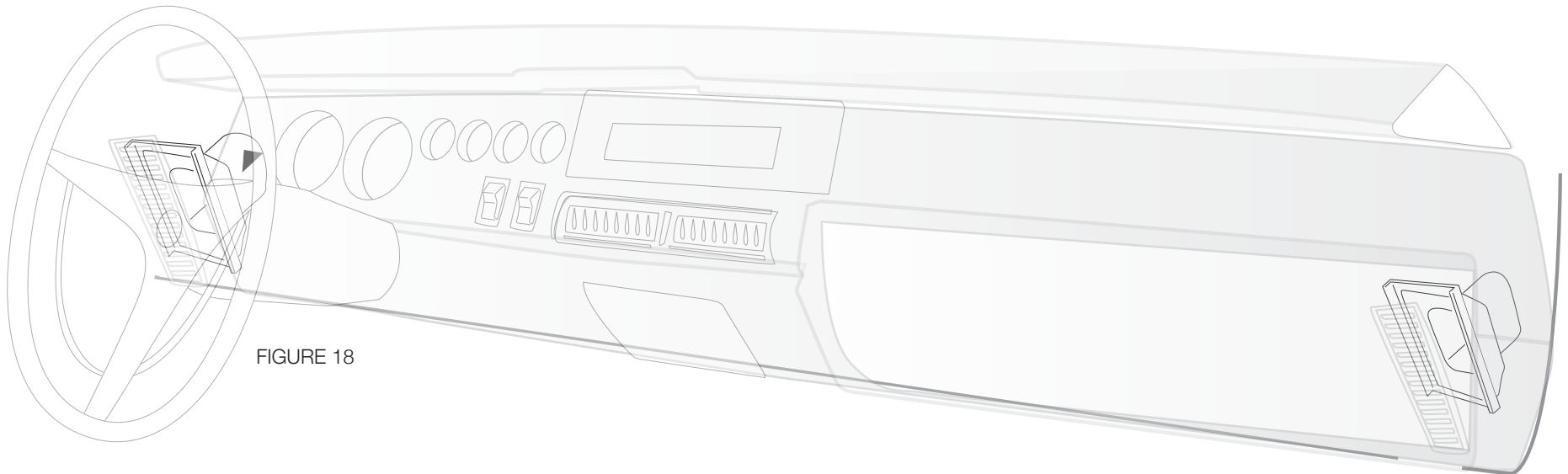
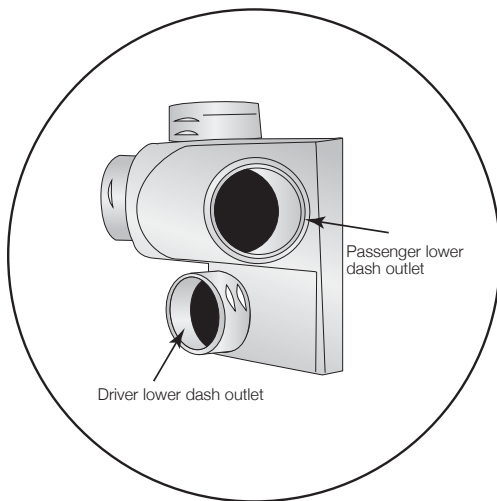

FIGURE 18



TECH TIPS



During installation of the hoses be aware of the eventual movement of the wiper arm components. Also, the smoother the route of the flex hoses the better the airflow.

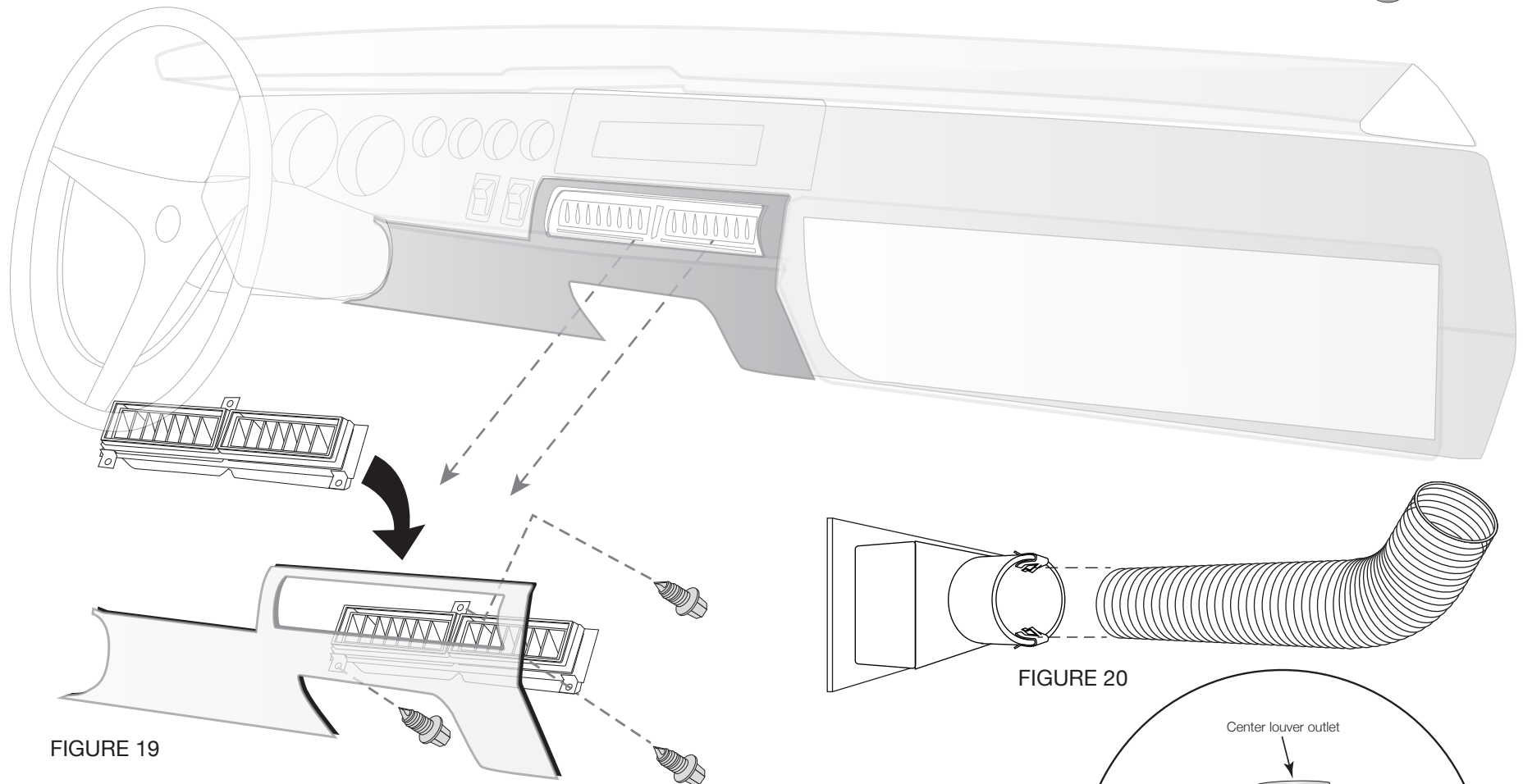
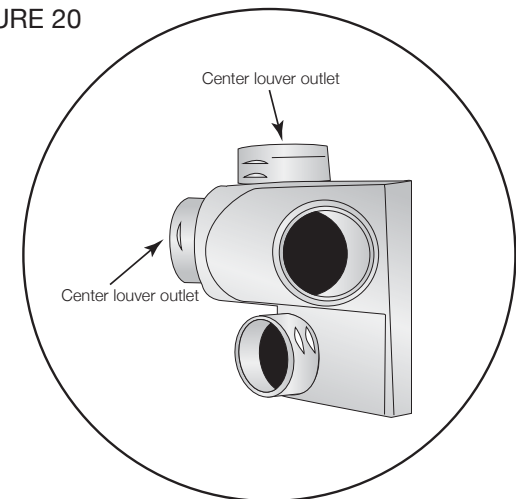

FIGURE 19

FIGURE 20

Bag Kit G: In order to adapt to your OEM center louver you will need to utilize our center louver and adapter. Remove the lower dash trim panel that contains the OEM center louver (see figure 19). Remove the OEM louver (retain the screws), insert your new center louver in it's place and secure with the OEM screws (see figure 19).

Go ahead and attach the duct hoses to the louver making sure the duct hose goes inside the louver, NOT the outside, and is held by attached clips (see figure 20) and route downward toward the evaporator.



Reinstall any of the interior you may have removed. This is a good time to make a final check that all the controls still move freely and that nothing is loose or hanging down. This completes the interior portion of the **Smart Series A/C** installation process.



Retaining all the non-reinstalled OEM parts is a good idea, but that's your choice.

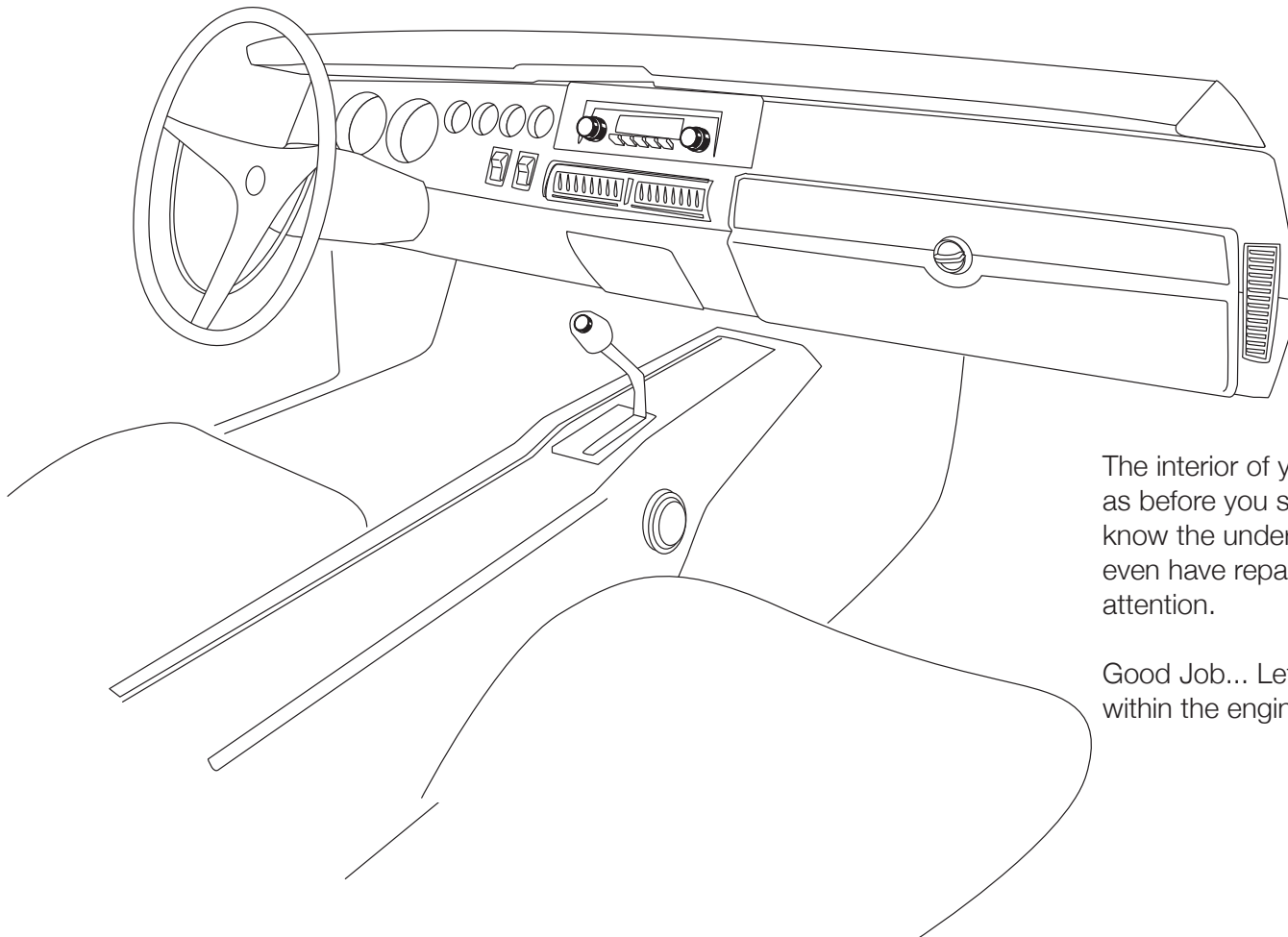

The interior of your car should look pretty much the same as before you started (or better). Plus you probably got to know the underside of your dash a lot better and might even have repaired or upgraded components that needed attention.

Good Job... Let's move on to the major components within the engine compartment....



THESE ARE THE PARTS YOU WILL NEED FOR THE ENGINE COMPARTMENT INSTALLATION

You'll find all of these parts within the main box

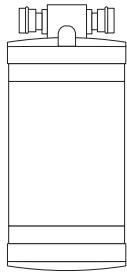

Drier
PN# 12-1008

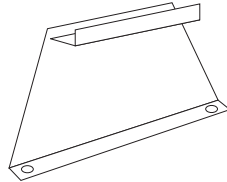

Condenser Bracket
PN# 0066-52

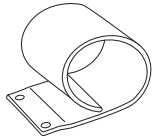

Drier Bracket
PN# 19-1003



MDS-03 Insulation

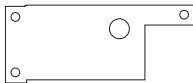

Condenser Bracket
PN# 0066-51

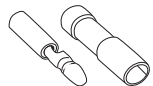

Splice and
Bullet Connector

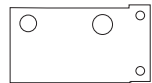

Condenser Bracket
PN# 0066-50

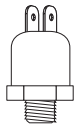

Pressure Switch

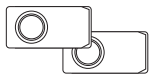

Two J-Clips



Bag of O-rings and
Mineral Oil Tube

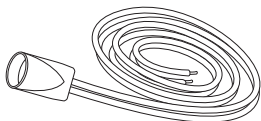

Pressure Switch Harness

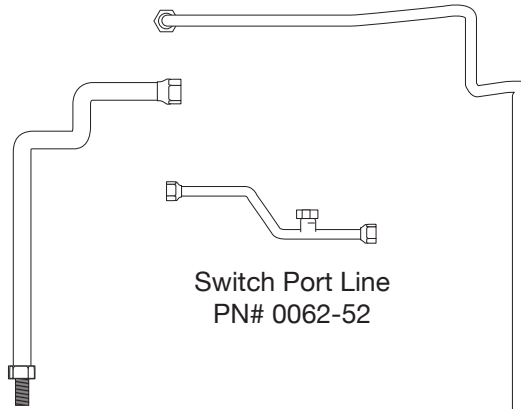

Switch Port Line
PN# 0062-52

#8 Discharge Tube
PN# 0066-53

#6 Liquid Tube
PN# 0062-50



#6 Hose
Clamp



#8 Hose
Clamp

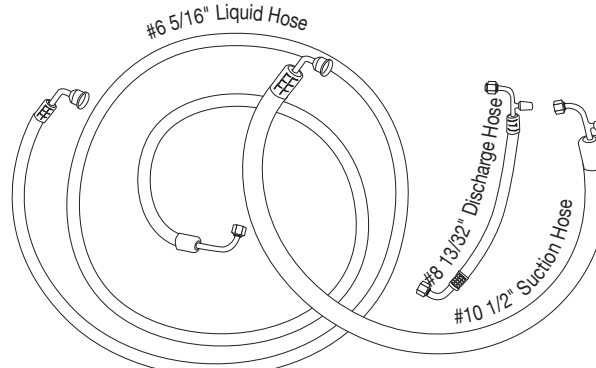

Three Refrigerant Hoses

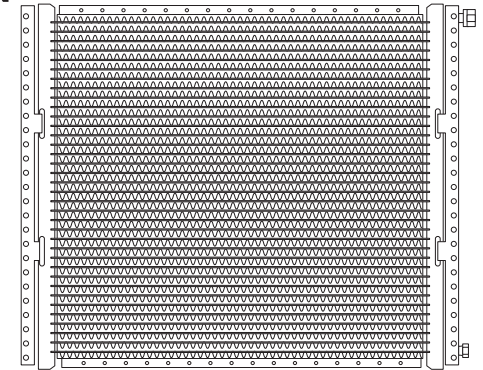

Condenser
PN# 11-1042



Four #10 X 1/4 Hex Head Screws



Four #10 - 16 x 3/4" Tek Screws



Four #1/4" 20 X 5/8" Bolts



Two #1/4" x 20 Flange Nuts

ENGINE COMPARTMENT INSTRUCTIONS

STEP ONE: IF YOU HAVE NOT ALREADY, DISCONNECT THE BATTERY.

STEP TWO: During the next installation section you'll be installing the condenser, drier, and routing the high/low pressure lines and the liquid line. Since much of this is installed in the OEM location for the condenser, you'll need to remove the center grill section, horn(s), and latch support assembly. Be sure to retain all the mounting screws – you'll reinstall these pieces in the exact reverse order with the OEM screws.

STEP THREE: Time to install the compressor kit. Included in your box is a premium compressor kit with all the parts you'll need to install the compressor. This kit includes easy to follow instructions specifically written for your engine. Once you've installed the complete compressor kit, continue on to the next step. We believe that this is the finest compressor kit available, and you're bound to notice the excellent fit and quality once this step is completed.

STEP FOUR: Install the Switch Port Line at the tube coming thru the firewall. Install the high pressure switch into the port on the Switch port line. **NOTE:** Tighten connections at either end using supplied o-rings on both ends and a few drops of mineral oil to each o-ring. Go ahead and plug the pressure switch harness into the switch at this time (black electrical boot with two long white wires. See figure 21).

This will give you the correct location for installing the drier. Place the included drier bracket over the drier, and mount the drier to the inner fender using the included Tek-screws.

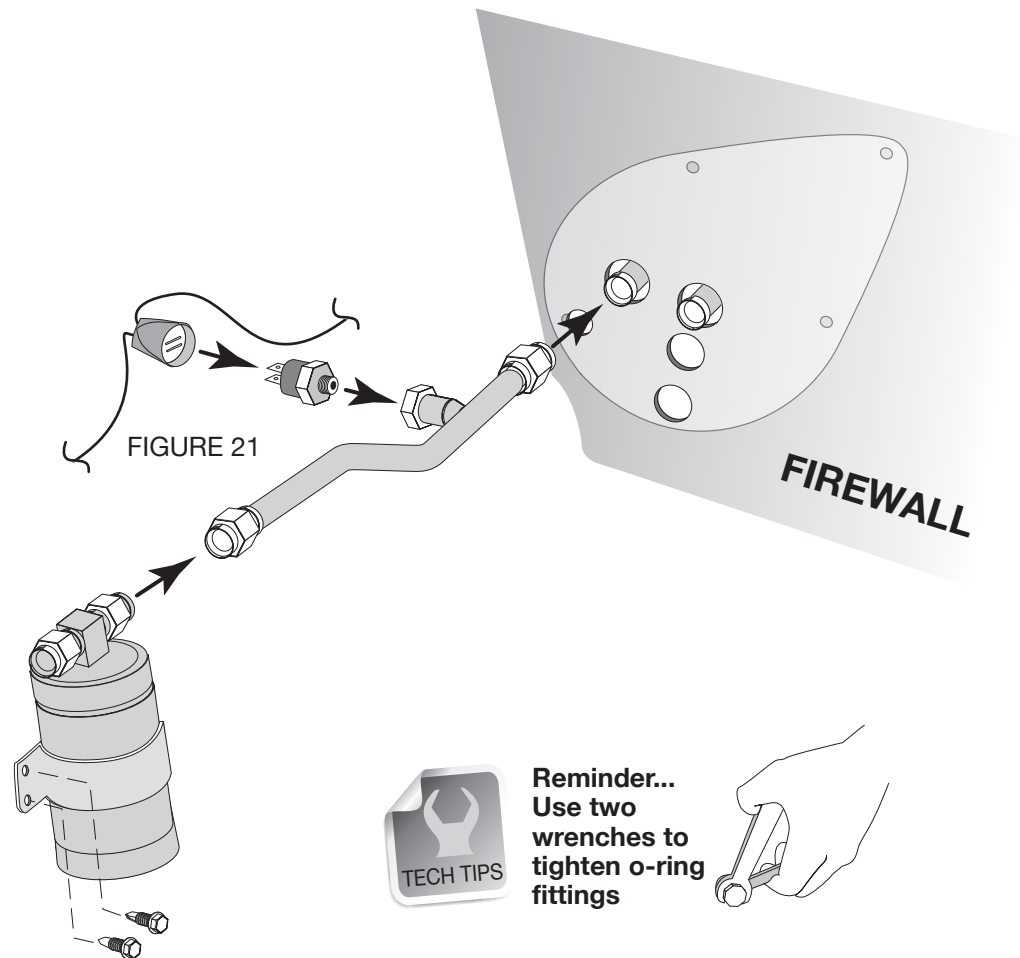

STEP FIVE: You can perform most of the following steps on a clean flat surface like a workbench. Lay the condenser down so that both hose connections are on the left side (the larger connection will be on top). Install the upper condenser brackets (A) using the included #10 x 1/4 hex screws. Both brackets are installed at the very top of the condenser, and from the backside. These brackets have holes that exactly correspond to bolts that are in the OEM radiator support (see figure 22).

STEP SIX: We've included a new lower condenser bracket (B). Locate the lower mounting bracket to bottom rail in front of the radiator. Attach two 1/4"-20 j-clip to the frame rail over the existing holes, and secure with two 1/4" x 20 x 5/8" hex screws. Peel the backing off of MDS03 insulation and attach to bracket channel.

STEP SEVEN: Place the condenser into place and secure with a 1/4"-20 x 5/8" hex head screw and a 1/4 x 20 flange nut thru the existing holes in the radiator support on both sides (both brackets are secured in the same way).

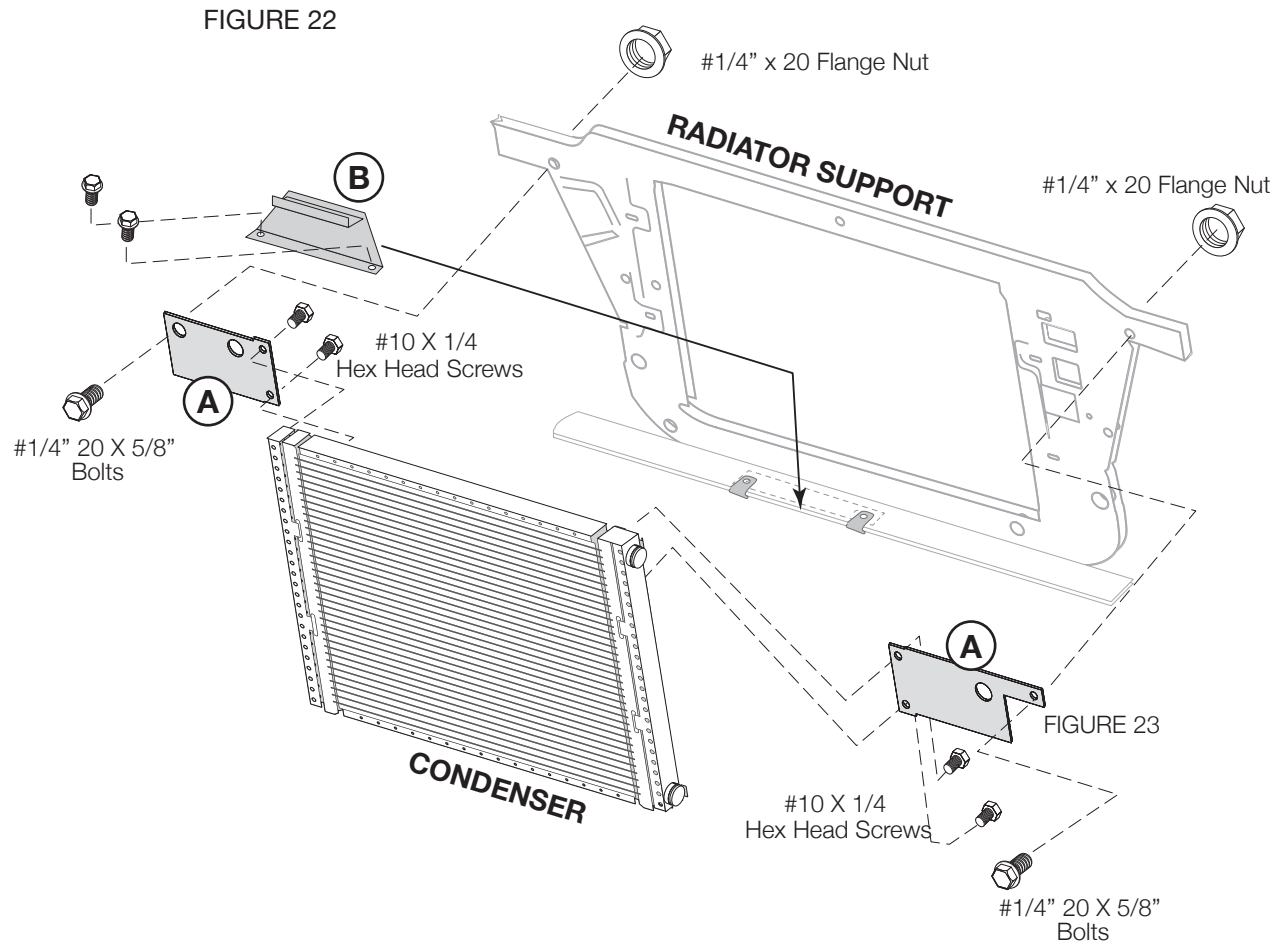

STEP EIGHT: You can now jog the discharge and liquids lines thru the existing upper rectangular hole in the radiator support, and then secure to the condenser. The longer line will be attached to the lower port on the condenser. The shorter line is attached to the upper port on the condenser. Test fit the routing before securing the fittings (see figure 23). **NOTE:** Tighten connections at either end using supplied o-rings on both ends and a few drops of mineral oil to each o-ring.

We've included two hose clamps which you can use to secure the lines to the drivers side inner fender area. Secure clamps with two #10 x 3/4" Tek-screws (see figure 24).

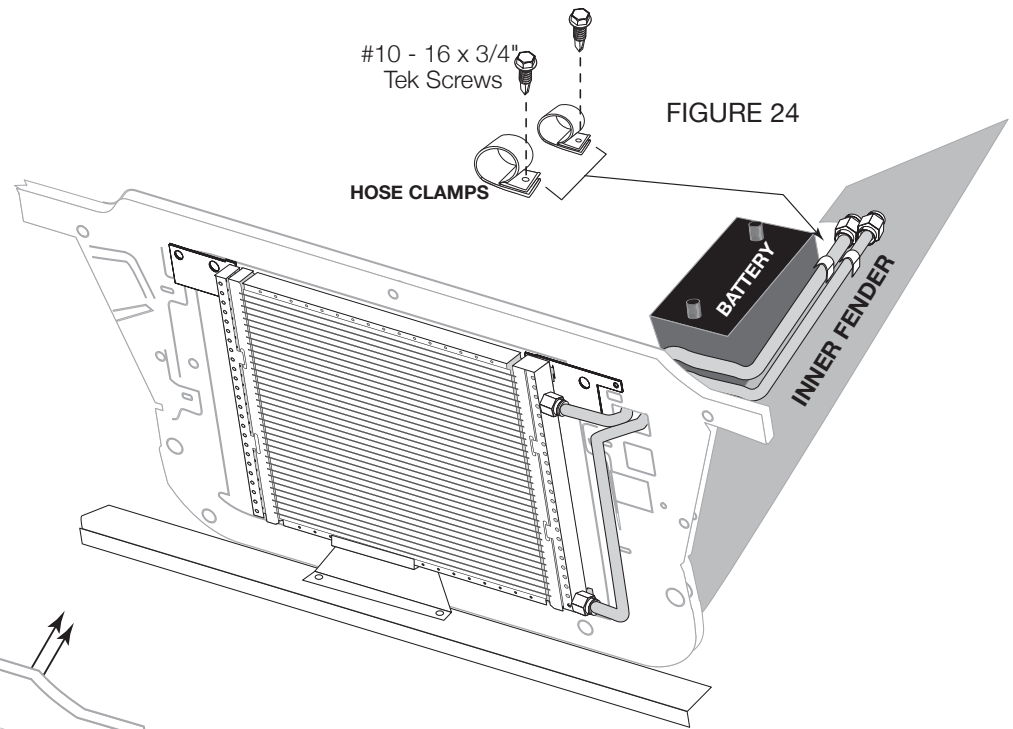
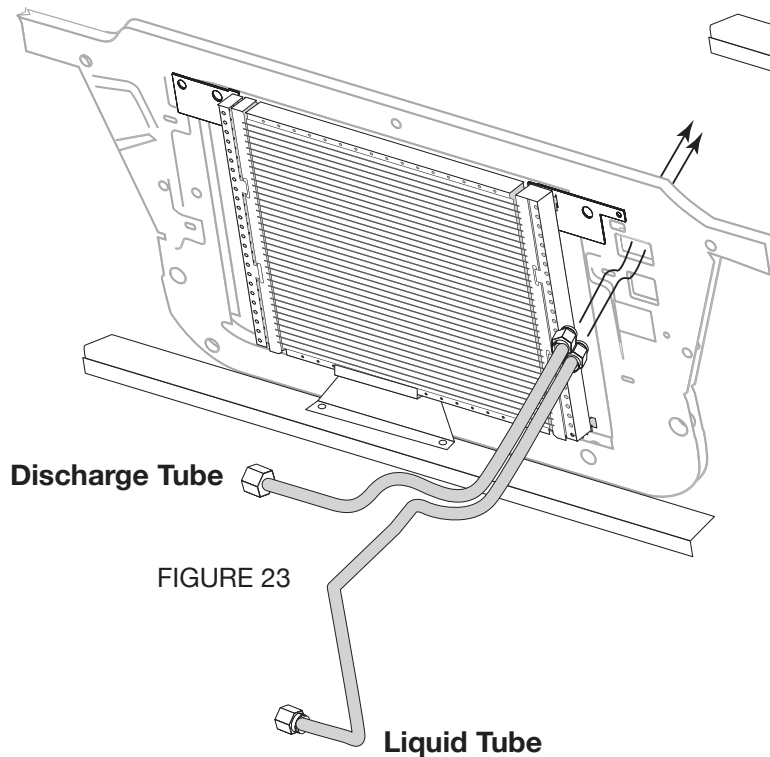

Reminder...
Use two
wrenches to
tighten o-ring
fittings

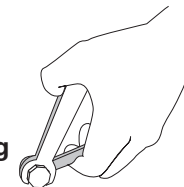

STEP NINE: CONNECTING THE HOSES (see figure 25):

- 1) Attach the #8 Discharge Hose (13/32") from the connection coming thru the support and route to the compressor. Tighten fittings using o-rings and mineral oil provided.
- 2) Attach the #6 liquid hose (5/16") from the connection coming thru the support and route to the drier. Tighten fittings using o-rings and mineral oil supplied in kit.
- 3) Attach the #10 suction hose (1/2") to the compressor and route to the last remaining connection coming thru the firewall. Tighten fittings using o-rings and mineral oil supplied in the kit.

TIPS: Route your lines so they will not interfere with moving parts or fall onto excessively hot components.

Double check all fittings before the initial servicing of your system. Loose fittings are the number one cause of leaks.

FIGURE 25

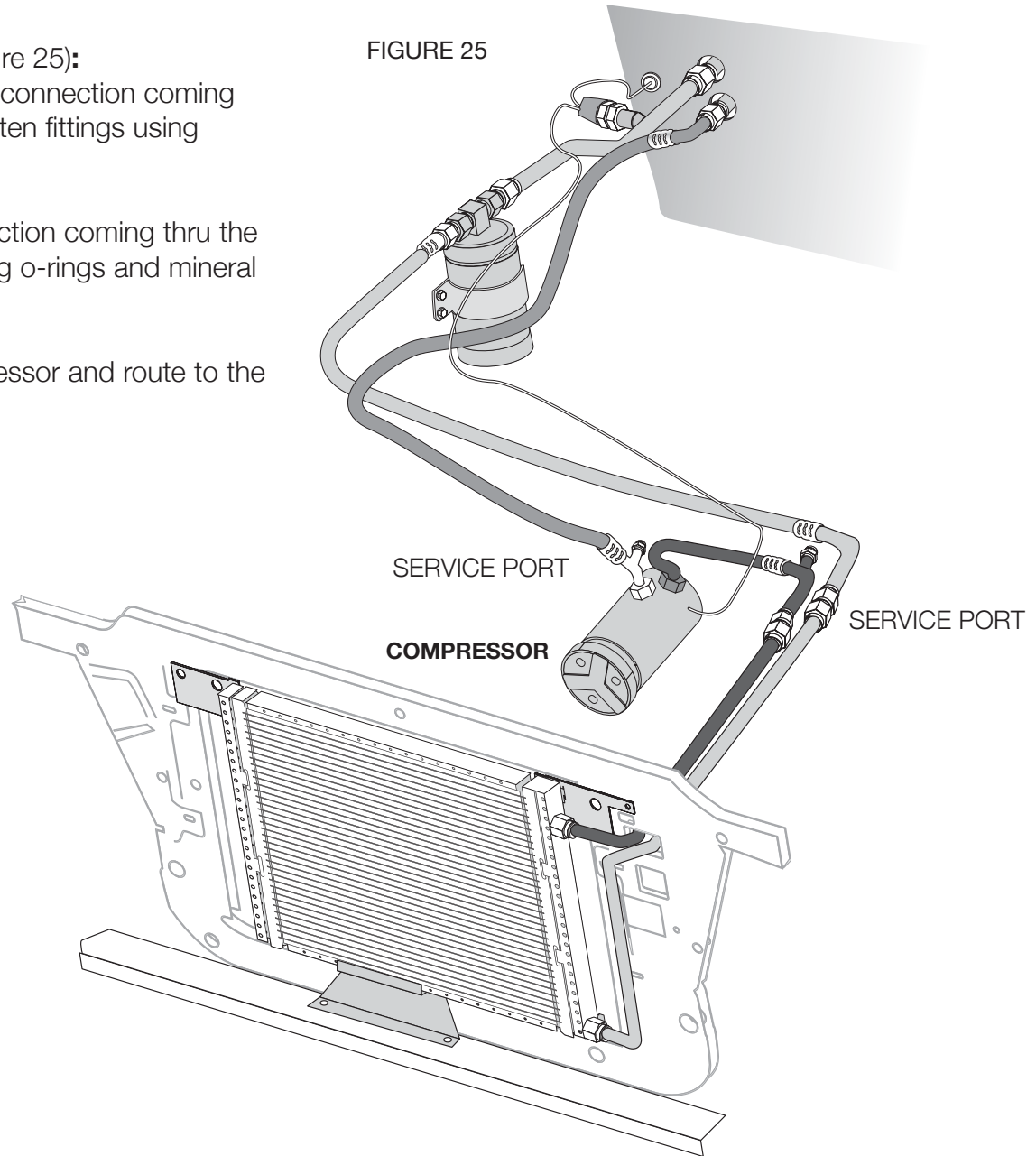

New A/C System Preparation... A MUST READ!

Please read through these procedures before completing this new A/C system charging operation.

A licensed A/C technician should be utilized for these procedures to insure that your new system will perform at it's peak, and that your compressor will not be damaged.



- 1) Your radiator/cooling system is an integral part of your new system. Please insure that you have a 50/50 mix of distilled water and antifreeze. The heater coil **MUST** be purged (cycle heater control valve) to make sure no water, without antifreeze, is in the heater coil before you charge the A/C system.
- 2) Evacuate the system for 45 minutes (minimum).
- 3) **Your new compressor MUST be hand-turned 15-20 revolutions before and after charging with liquid. Failure to do this may cause the reed valves to become damaged** (this damage is NOT covered by your warranty).
- 4) Your new system requires 134a refrigerant. It will require 1.5 lbs (or 24 oz).
- 5) Your new compressor comes charged with oil - NO additional oil is needed.
- 6) Insure that the new belt is tight.
- 7) **DO NOT CHARGE SYSTEM WITH LIQUID REFRIGERANT!**

RECOMMENDED TEST CONDITIONS: (After system has been fully charged and tested for basic operation)

- Determine the temperature outside of the car
- Connect gauges or service equipment to high/low charging ports
- Place blower fan switch on medium
- Close all doors and windows on vehicle
- Place shop fan directly in front of condenser
- Run engine idle up to approx. 1500 rpm

ACCEPTABLE OPERATING PRESSURE RANGES:

1. HIGH-SIDE PRESSURES (150-275 PSI)
2. LOW-SIDE PRESSURES (10-25 PSI in a steady state)

Readings above are based on an ambient temperature of 90° with an adequate airflow on condenser

CENTERLINE OF THE OIL FILL BOLT

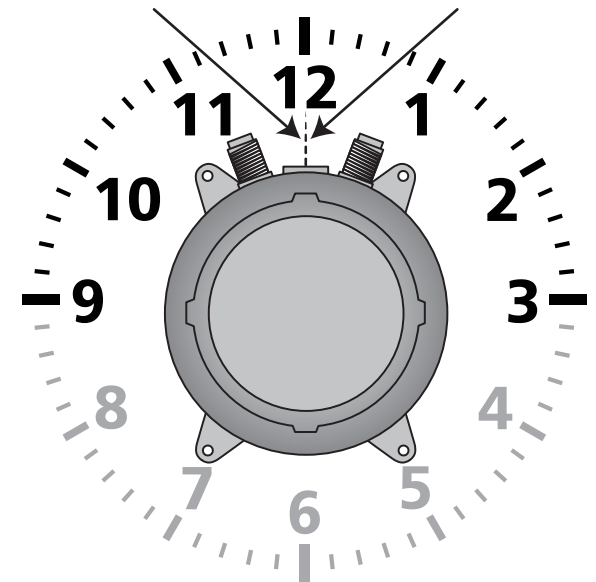

CAUTION! When mounting your compressor and/or adjusting the belt use caution. Mount by using the centerline of the oil fill plug as your guide. The compressor can **ONLY** be mounted in between the 9 to 3 positions. **DO NOT** mount in between the 4 to 8 positions.

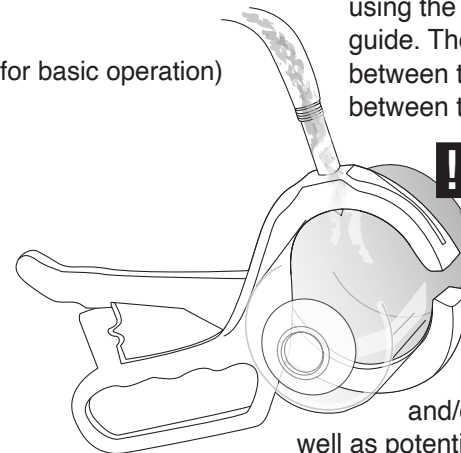

Do NOT tilt, shake or turn refrigerant can upside-down OR use a charging station to install refrigerant while the engine is running.

Doing so will direct liquid refrigerant into the compressor piston chamber, causing damage to reed valves and/or pistons and/or other components, as well as potentially seizing the compressor. Allow a minimum of 30 minutes for liquid to "boil off." You must hand turn the compressor hub (not the pulley) a minimum of 15 complete revolutions prior to starting the engine with the clutch engaged.

TROUBLESHOOTING GUIDE

TEST CONDITIONS USED TO DETERMINE SYSTEM OPERATION

(THESE TEST CONDITIONS WILL SIMULATE THE AFFECT OF DRIVING THE VEHICLE AND GIVE THE TECHNICIAN THE THREE CRITICAL READINGS THAT THEY WILL NEED TO DIAGNOSE ANY POTENTIAL PROBLEMS).

- B. CONNECT GAUGES OR SERVICE EQUIPMENT TO HIGH/LOW CHARGING PORTS.
- C. PLACE BLOWER FAN SWITCH ON MEDIUM.
- D. CLOSE ALL DOORS AND WINDOWS ON VEHICLE.
- E. PLACE SHOP FAN IN FRONT OF CONDENSER.
- F. RUN ENGINE IDLE UP TO 1500 RPM.

ACCEPTABLE OPERATING PRESSURE RANGES (R134A TYPE)

- 1. HIGH-SIDE PRESSURES (150-275 PSI) **Note- general rule of thumb is two times the ambient (daytime) temperature, plus 15-20%.*
- 2. LOW-SIDE PRESSURES (10-25 PSI in a steady state).

CHARGE AS FOLLOWS: R134A = 24 OZ.
NO ADDITIONAL OIL IS NECESSARY IN OUR NEW COMPRESSORS.

TYPICAL PROBLEMS ENCOUNTERED IN CHARGING SYSTEMS

NOISY COMPRESSOR. A noisy compressor is generally caused by charging a compressor with liquid or overcharging

- A. If the system is overcharged both gauges will read abnormally high readings. This is causing a feedback pressure on the compressor causing it to rattle or shake from the increased cylinder head pressures. System must be evacuated and re-charged to exact weight specifications.
- B. Heater control valve installation - Installing the heater control valve in the incorrect hose. Usually when this occurs the system will cool at idle then start to warm up when raising the RPM's of the motor. THE HEATER CONTROL IS A DIRECTIONAL VALVE; MAKE SURE THE WATER FLOW IS WITH THE DIRECTION OF THE ARROW. As the engine heats up that water transfers the heat to the coil, thus overpowering the a/c coil. A leaking or

faulty valve will have a more pronounced affect on the unit's cooling ability. Installing the valve improperly (such as having the flow reversed) will also allow water to flow through, thus inhibiting cooling. Check for heat transfer by disconnecting hoses from the system completely. By running down the road with the hoses looped backed through the motor, you eliminate the possibility of heat transfer to the unit.

- C. Evaporator freezing - Freezing can occur both externally and internally on an evaporator core. External freeze up occurs when the coil cannot effectively displace the condensation on the outside fins and the water forms ice (the evaporator core resembles a block of solid ice), it restricts the flow of air that can pass through it, which gives the illusion of the air not functioning. The common cause of external freezing is the setting of the thermostat and the presence of high humidity in the passenger compartment. All door and window seals should be checked in the event of constant freeze-up. A thermostat is provided with all units to control the cycling of the compressor.
- D. Internal freeze up occurs when there is too much moisture inside the system. The symptoms of internal freeze up often surface after extended highway driving. The volume of air stays constant, but the temperature of the air gradually rises. When this freezing occurs the low side pressure will drop, eventually going into a vacuum. At this point, the system should be checked by a professional who will evacuate the system and the drier will have to be changed.
- E. Inadequate airflow to condenser - The condenser works best in front of the radiator with a large supply of fresh air. Abnormally high pressures will result from improper airflow. Check the airflow requirements by placing a large capacity fan in front of the condenser and running cool water over the surface. If the pressures drop significantly, this will indicate the need for better airflow.
- F. Incorrect or inadequate condenser capacity - Incorrect condenser capacity will cause abnormally high head pressures. A quick test that can be performed is to run cool water over the condenser while the system is operating, if the pressures decrease significantly, it is likely a airflow or capacity problem.
- G. Expansion valve failure - An expansion valve failure is generally caused by dirt or debris entering the system during assembly. If an expansion valve fails it will be indicated by abnormal gauge readings. A valve that is blocked will be indicated by high side that is unusually high, while the low side will be unusually low or may even go into a vacuum. A valve that is stuck open will be indicated by both the high and low pressures rising to unusually high readings, seeming to move toward equal readings on the gauges.
- H. Restrictions in system - A restriction in the cooling system will cause abnormal readings on the gauges. A high-side restriction (between the compressor and the drier inlet) will be indicated by the discharge gauges reading excessively high. These simple tests can be performed by a local shop and can help determine the extent of the systems problem.

Trouble Shooting Your Classic Auto Air A/C System

PROBLEM: system is not cooling properly

ISSUE: cold at idle, warmer when raising engine RPM's

Make sure the Water Valve is positioned correctly

The water valve is a directional valve and should be installed with the arrow pointing towards the water pump, it should be connected to the heater hose that runs from the heater core to the water pump. If the water valve is connected to the incorrect hose it allows water to circulate through the system via the heater core over powering the cooling effect of the A/C coil, (normally the air conditioning is functioning properly).

Step 1: Check placement of the water valve, correct if needed. (In some cases changing the location of the water valve may not fix the above problem.) Continue to next step.

Step 2 If changing the location of the water valve does not rectify the issue, then possibly the water valve is permanently damaged and may need to be replaced. To check the integrity of the water valve completely remove the water hoses for the heater core and "loop" together. (This will remove the heater system completely from the possibilities) If the system now cools, replace the water valve

Verify Adequate Air Flow to Condenser

For an air conditioning system to function properly there has to be adequate airflow across the condenser. The function of the condenser is to dissipate heat, without proper airflow your system will not cool correctly in the cabin of your vehicle.

Step 1: connect gauges to a/c hoses. The pressures should be: with the ambient temp is 90, low side pressures should be between 10-25 psi, high side pressures should be between 150-275 psi

Step 2: IF the low side pressures are normal and the high side pressures are high then there might be an airflow issue, continue to next step.

To test air flow to Condenser do the following three tests:

1. Place a piece of paper on the condenser with the car in idle and see if paper is held in place.
2. With car in idle, attach gages, and place a large capacity fan in front of

the condenser. What happens to the pressures?

3. With car still in idle and gages attached, pour water down the front of the condenser. What happens to the pressures?

If the paper is held in place you are at least getting some air flow. If the high side decreases during test 2 & 3 then your condenser is not getting enough air which is causing your system to not cool properly. To correct this issue you will need a more powerful mechanical fan.

Step 3: Confirm correct Refrigerant charge in System

All of our systems should be charged with 24 oz or 1.5 lbs of R134A Refrigerant only. If overcharged you will need to evacuate the system and recharge with the correct amount.*

What measurements mean:

Low Temp and High Pressure seem to be equal...

You have a malfunctioning expansion valve that is stuck open.

High Side is extremely high and Low Side is extremely low (possibly into vacuum)...

There is a blockage in the system. Remove hoses and blow compressed air through in both directions. If pressures don't change its possible that your expansion valve is stuck closed and would have to be replaced.

*Compressor Concerns:

This is often misdiagnosed as a problem for the system not cooling properly. If you have a noisy compressor it is due to improper charging of refrigerant. An overcharged (more than 24 oz or 1.5 lbs R134A) compressor can cause rattling. If charged with pure liquid there is a high probability you have bent reed valves that are causing tapping sound.

SCAN QR code
with your mobile camera

Get the technical support you want the moment you need it, with no wait times. Simply **SCAN** the **QR code** and be directly taken to our support section to troubleshoot all things A/C.

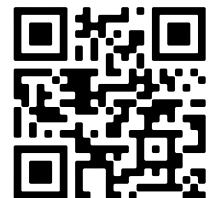



Classic Auto Air Hardware Reference Guide

This is our basic line-up of hardware. No single kit will not contain all of these, but you can use this guide to match-up hardware for shape and size (all of these are actual size.)

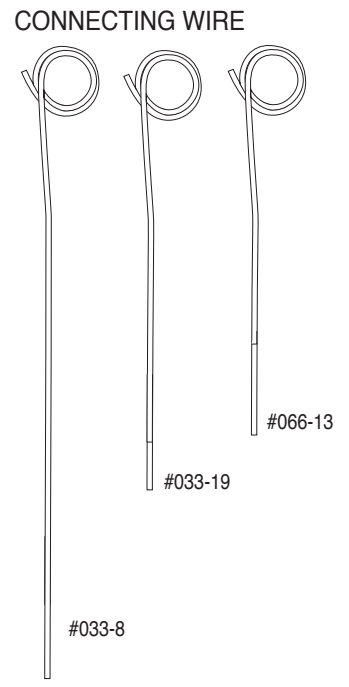
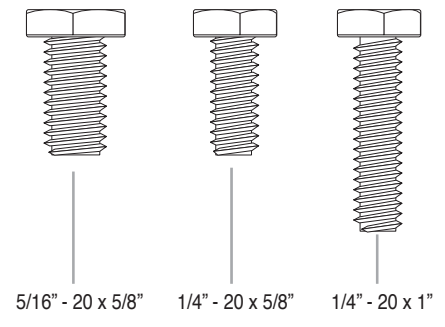
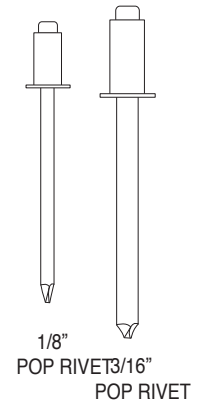
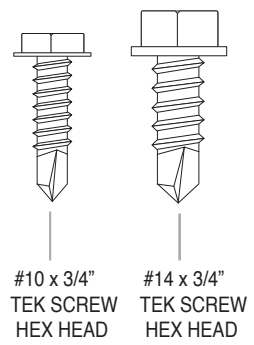
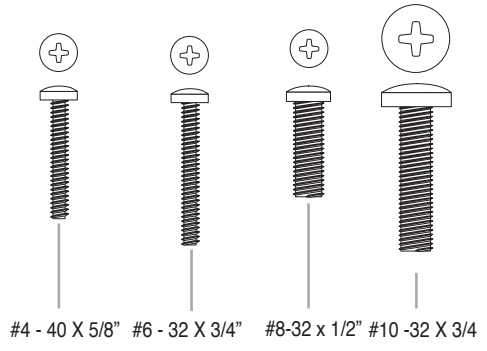
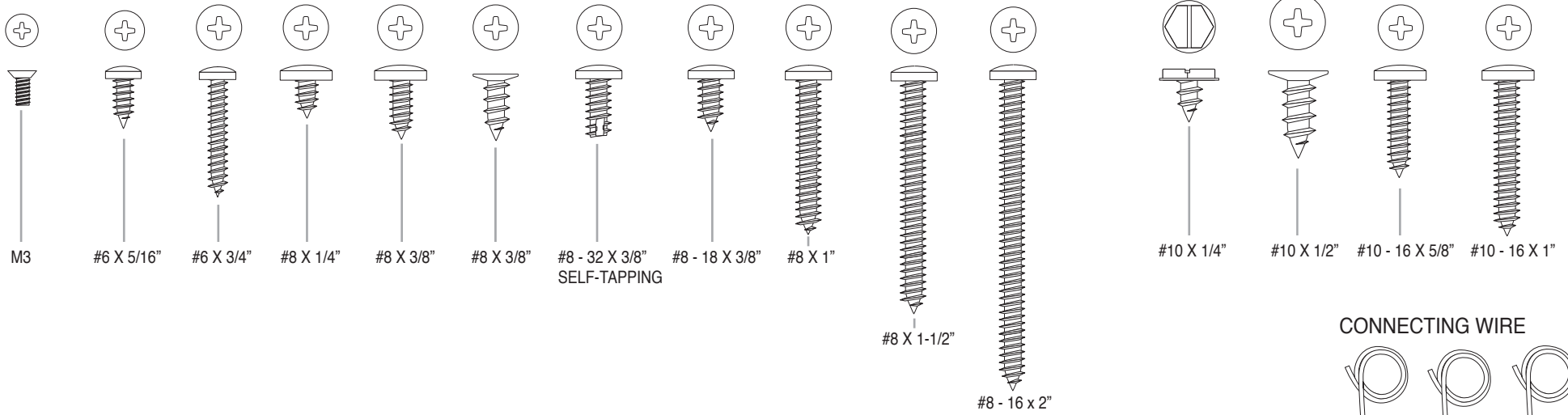

LOCK NUTS



NUTS AND WASHERS



Classic Auto Air Hardware Reference Guide

O-RINGS

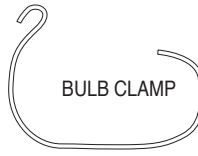
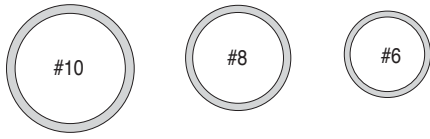

BULB CLAMP

CLIPS

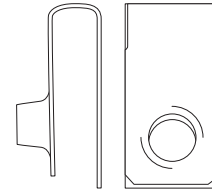

J-CLIP

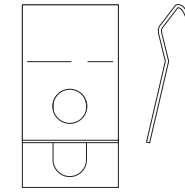

CABLE CLIP

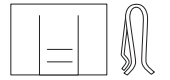

DUCT HOSE CLIP

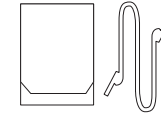

S-CLIP

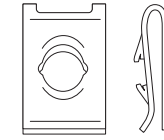

U-CLIP 10 X 32

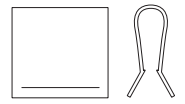

U-TYPE FASTENER

GROMMETS

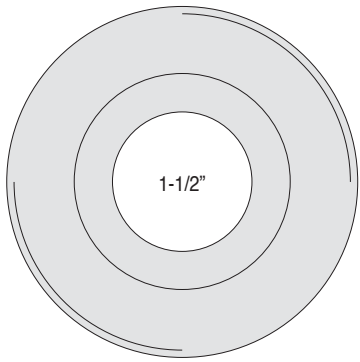

1-1/2"

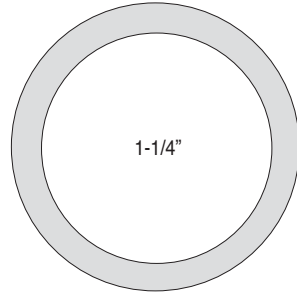

1-1/4"

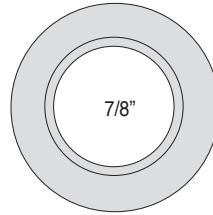

7/8"

HOLE PLUGS

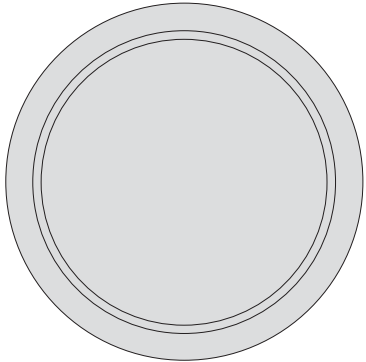

1-1/2"

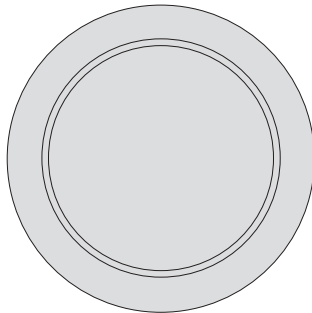

1-1/4"

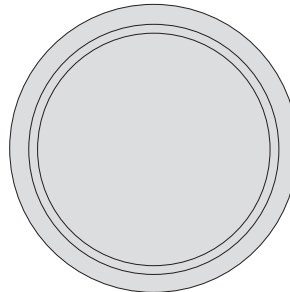

1-1/8"

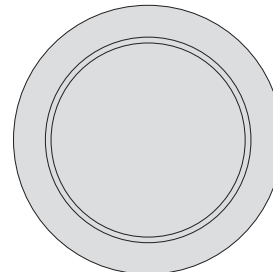

1"

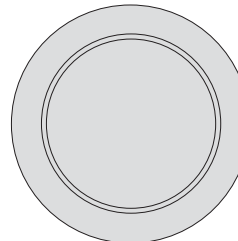

7/8"

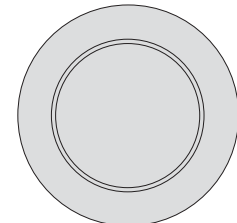

3/4"

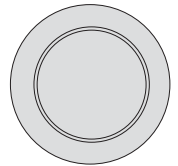

1/2"

HOSE CLAMPS

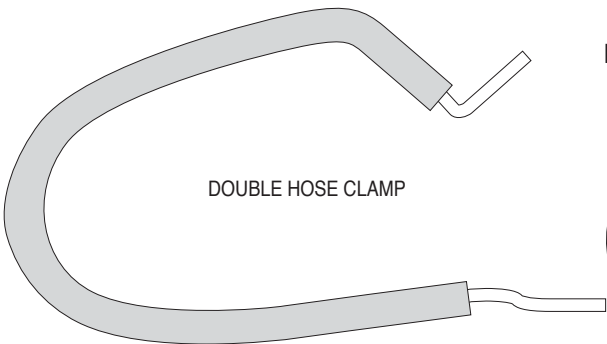

DOUBLE HOSE CLAMP

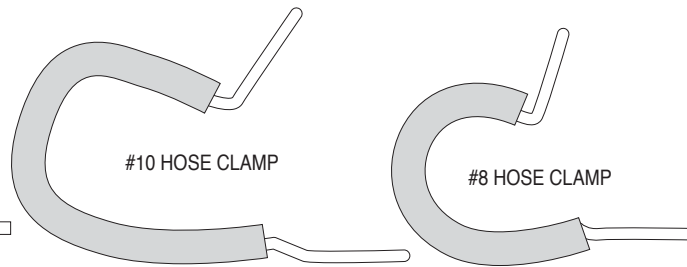

#10 HOSE CLAMP

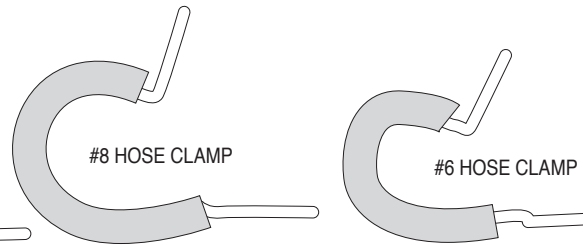

#8 HOSE CLAMP

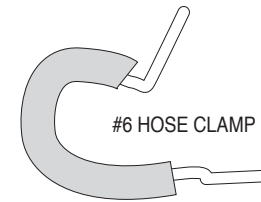

#6 HOSE CLAMP



WORM GEAR CLAMP

