



# *Installation Manual*

---

# *1970-1978 Camaro*

DOCUMENT #1-3057

©2023 Classic Auto Air / 12.23







# ***Congratulations...***

You have just purchased the highest quality, best performing A/C system ever designed for your Camaro.

To obtain the high level of performance and dependability our systems are known for, please pay close attention to the following instructions. Our installation steps and procedures are derived from a long history of research and development and the combined experience achieved thru thousands of successful installations (and feedback from customers like you). Please remember that our #1 goal is that you'll have a successful installation and a system that performs at a very high level for many years to come.

Before starting, read the instructions carefully, from beginning to end, and follow the proper sequence. On the next page you'll find a safety and general checklist that you should read before starting your installation.

Again, thank you from our entire staff.



## Check List, Pre-Installation:

- Before beginning the installation check the shipping box for the correct components. YOUR BOXED UNIT INCLUDES A LIST OF MAJOR COMPONENTS AND A LIST OF BAGGED PARTS. We have a 5 stage check process to make sure you have everything you'll need.
- If your vehicle has been or is being modified, some procedures will need to be adjusted to fit your particular application.**
- A basic cleaning of the engine compartment and interior before beginning will make things go more smoothly.
- Check condition of engine mounts. Excessive engine movement can damage hoses to A/C and/or heater.
- Before starting, check vehicle interior electrical functions (interior lights, radio, horn, etc). Make a note of anything that does not work as it's supposed to. During the installation you might find the opportunity to repair or upgrade non-working or out of date components. When you're ready to start the installation, **DISCONNECT THE BATTERY FIRST.**
- Drain the radiator. Retain the coolant and reuse, or dispose of properly.
- SAFETY FIRST: Wear eye protection while drilling/cutting, deburr sharp edges, and never get in a hurry or force a part.
- Tools: Your installation only requires the basic tools everyone has in their garage, nothing exotic or specific to A/C or Heat equipment.

## Procedures, During Installation:

- Fittings: Use one or two drops of mineral oil (supplied with your kit) on ALL rubber o-rings, threads and rear of bump for o-ring where female nut rides. Do not use thread tape or sealants.
- Measure twice (or more), cut once
- Should you have any technical questions, or feel you have defective components (or missing items), call us immediately, we will be glad to assist you. Our toll-free number is listed on every page, we're here to help!**

***YOU CAN NOW BEGIN THE INSTALLATION...***

## A Basic Overview of Automotive A/C....

- 1 **Evaporator with Blower Fan** In order to remove the heat from the air in the vehicle, the A/C evaporator allows the refrigerant to absorb the heat from the air passing over it. The blower fan moves cool air out into the car interior.
- 2 **Compressor** The compressor pumps and circulates the refrigerant through the system.
- 3 **Condenser** The condenser is a heat exchanger mounted at the front of the vehicle. Heat drawn out of the interior of the car is expelled here.
- 4 **Receiver/Drier** The drier not only dries refrigerant, it also filters the refrigerant and stores it under certain operating conditions.
- 5 **High Pressure Switch** A pressure switch is used to shut down the system if high or low pressure is detected, basically it acts as a safety switch.

The air conditioning system in your vehicle is comprised of a compressor, condenser, expansion valve, receiver/drier, and evaporator. Refrigerant (also known as Freon) is compressed in the compressor. In the condenser, gas is cooled to a liquid state and travels to the expansion valve. As the liquid refrigerant goes through the expansion valve it rapidly cools in the evaporator. A fan blows over the evaporator and cools the air that blows out your vents.

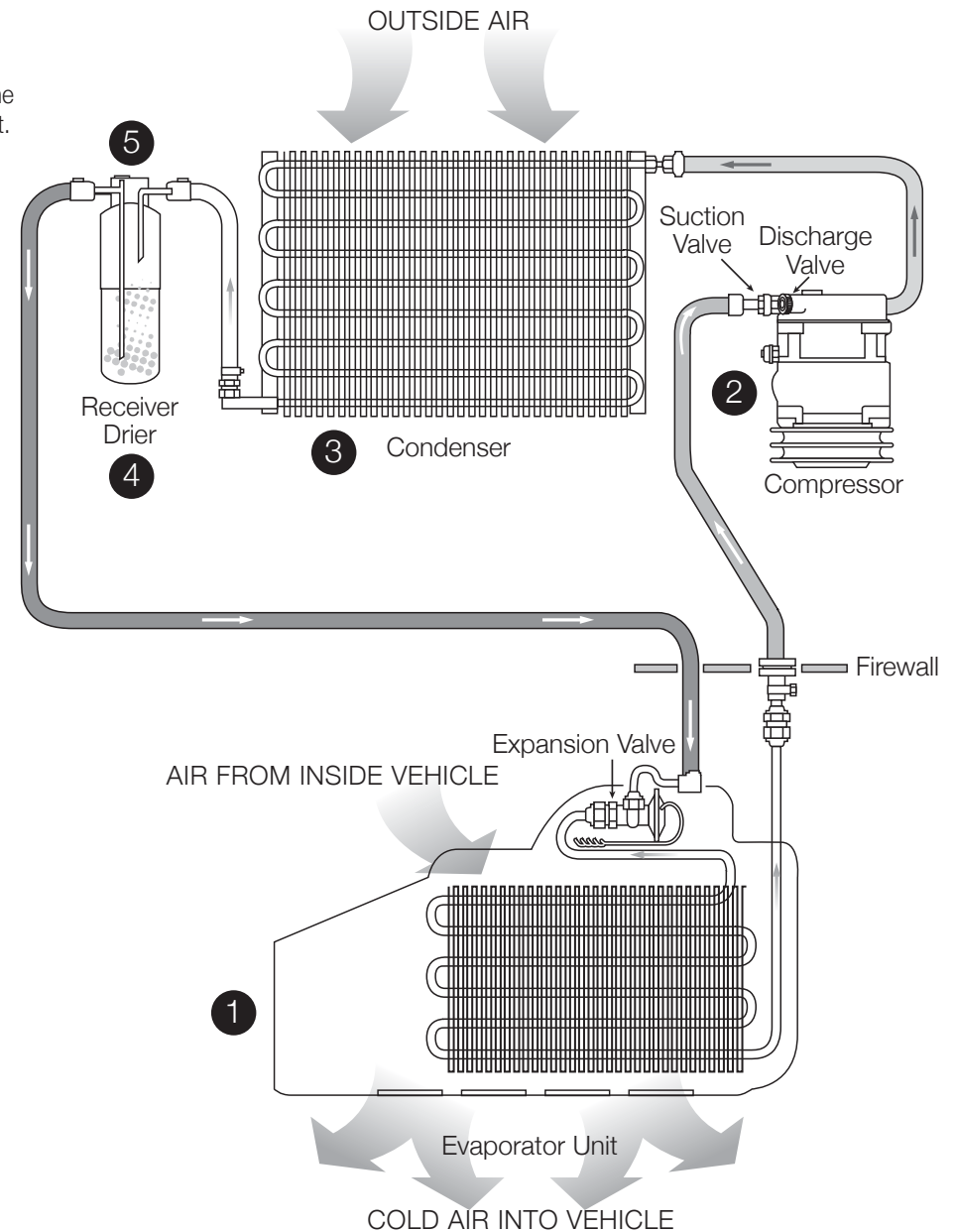

# Control & Operating Instructions

Your new **Perfect Fit-Smart Series A/C** system offers complete comfort capabilities in virtually every driving condition. This includes temperature control in all of the modes. This system also provides the ability to blend the air between Face, Heat, and Defrost modes simultaneously. To illustrate the various ways you can adjust the airflow direction and temperature - we've provided these handy illustrations and chart to show exactly how you can adjust your **Perfect Fit-Smart Series A/C** for maximum comfort...

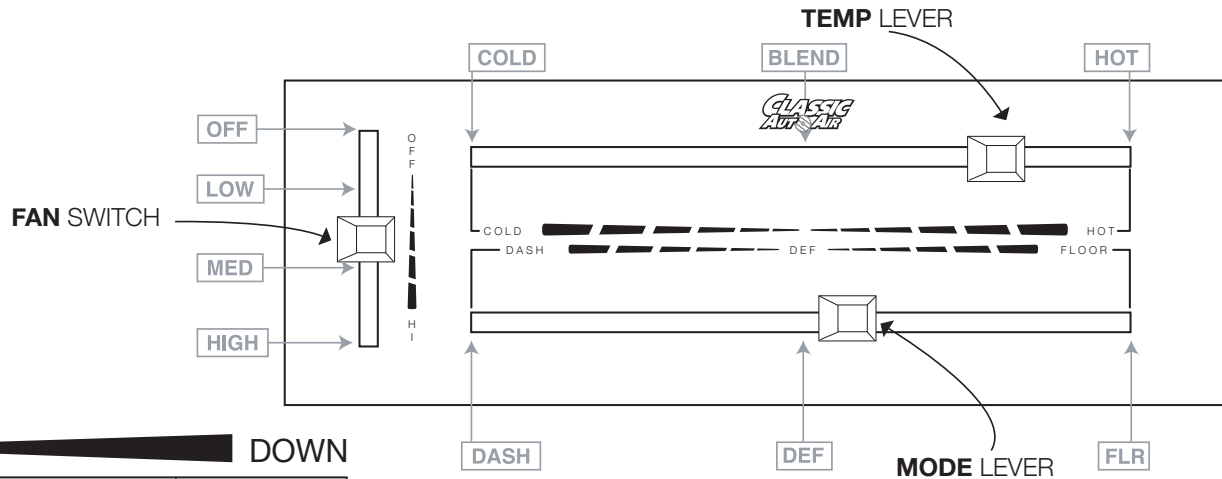

<b>FAN</b>	UP				DOWN
BLOWER	OFF	LOW	MED	HIGH	

<b>TEMP</b>	COLD											HOT
VALVE POSITION	CLOSED - 0%	OPEN - 10%	OPEN - 20%	OPEN - 30%	OPEN - 40%	OPEN - 50%	OPEN - 60%	OPEN - 70%	OPEN - 80%	OPEN - 90%	OPEN - 100%	
COMPRESSOR	ON	ON	ON	ON	ON	ON	ON	ON	ON	ON	OFF	

<b>MODE</b>	DASH											FLOOR
POSITION	Dash A/C 100%	Dash A/C 80% Defrost 20%	Dash A/C 60% Defrost 40%	Dash A/C 40% Defrost 60%	Dash A/C 20% Def 80%	Defrost 100%	Floor Defrost 20% 80%	Floor Defrost 40% 60%	Floor Defrost 60% 40%	Floor Defrost 80% 20%	Floor 100%	
COMPRESSOR	ON	ON	ON	ON	ON	ON	ON	ON	ON	ON	ON	

There are 11 levels of adjustment within the range of the DASH - DEF - FLOOR lever

# Familiarize yourself with the Evaporator



**Take a minute to familiarize yourself with the evaporator unit:**

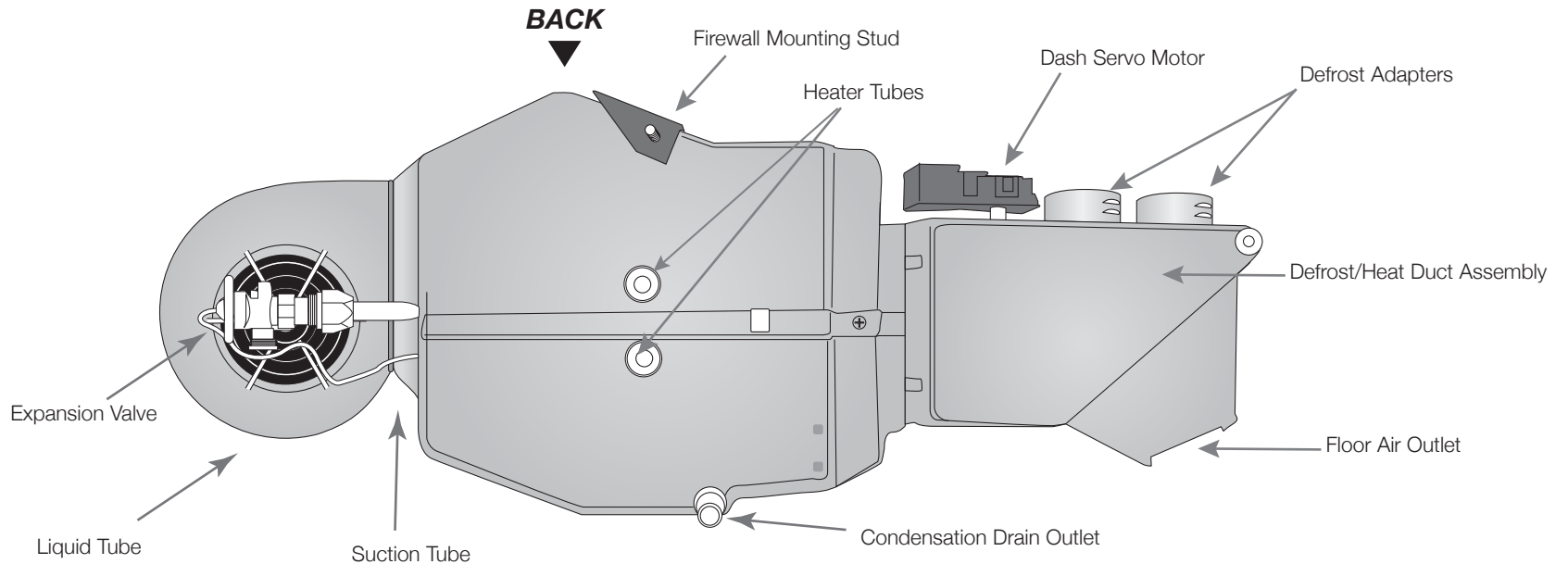
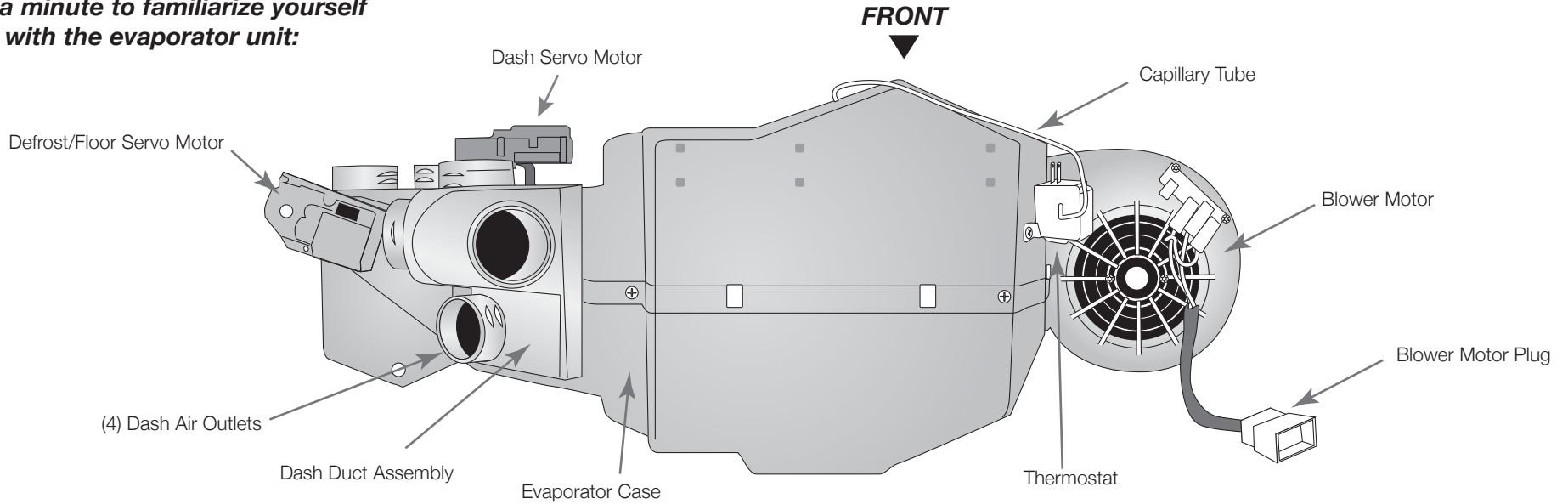



Remove Glovebox, Console (optional) Radio and Bezel, and set them aside for reinstall later (see figure 1).

The removal of the Original Heater Assembly can be accomplished by disconnecting three control cables. One is attached to the Heat/Defrost door (see figure 2). One is attached to the Temperature door, and one is attached to the Vent / Heat door (see figure 3). Disconnect the electrical harness from the assembly. Also remove attachment screw located in front of the air inlet (see figure 4).

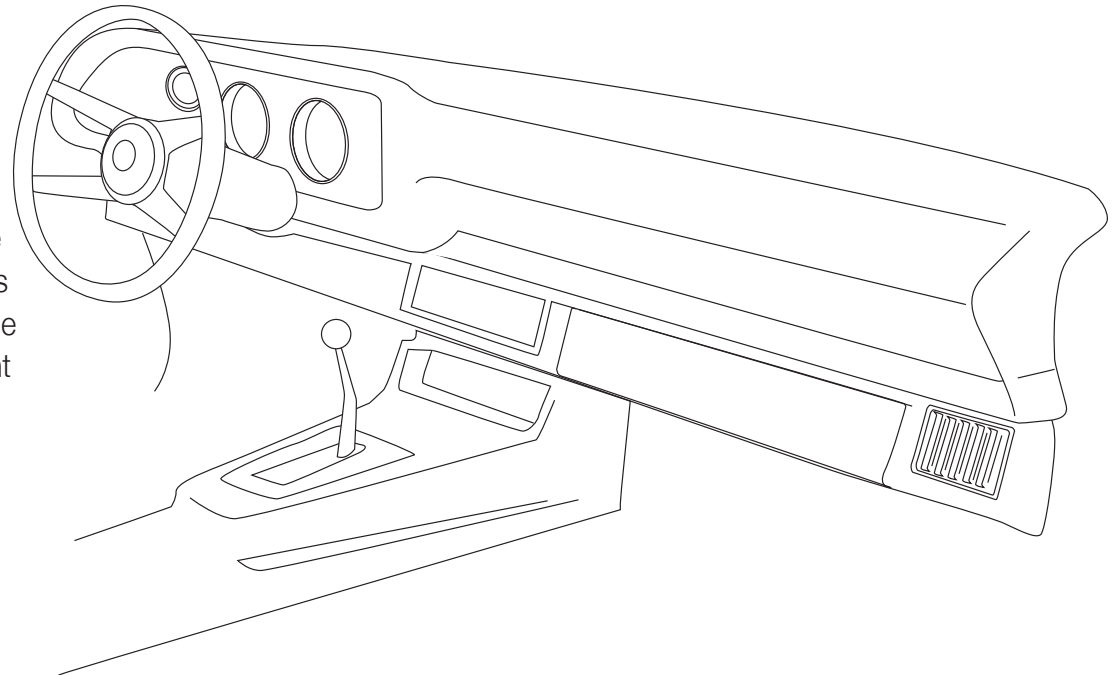

When retaining parts it's a good idea to store parts in a zip lock bag, labeled with info where the parts came from and what size/type of tool is needed to reinstall.

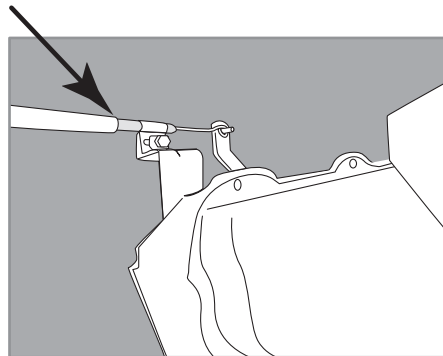

FIGURE 2

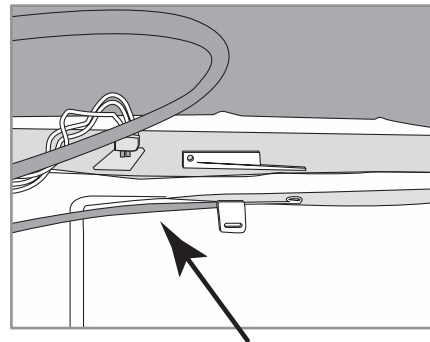

FIGURE 3

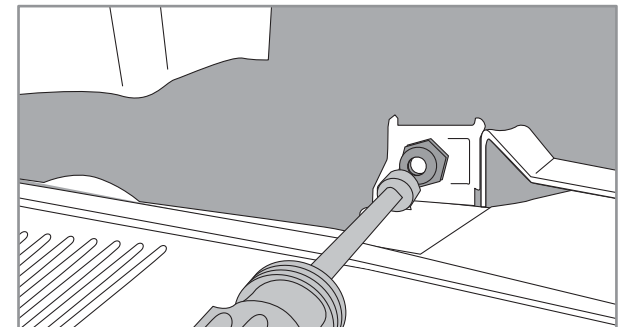

FIGURE 4



Disconnect the electrical harness at the resistor block (see Figure 5).

Remove the OEM control head, which is held in with two screws. Retain the OEM screws.

Set the control head aside (you'll need the bezel later).

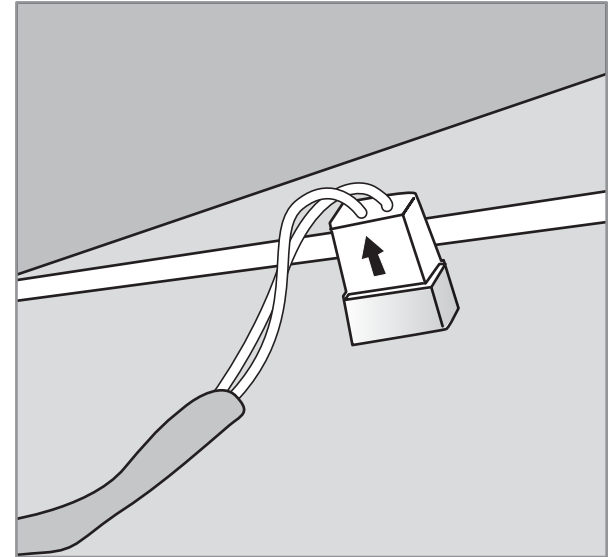
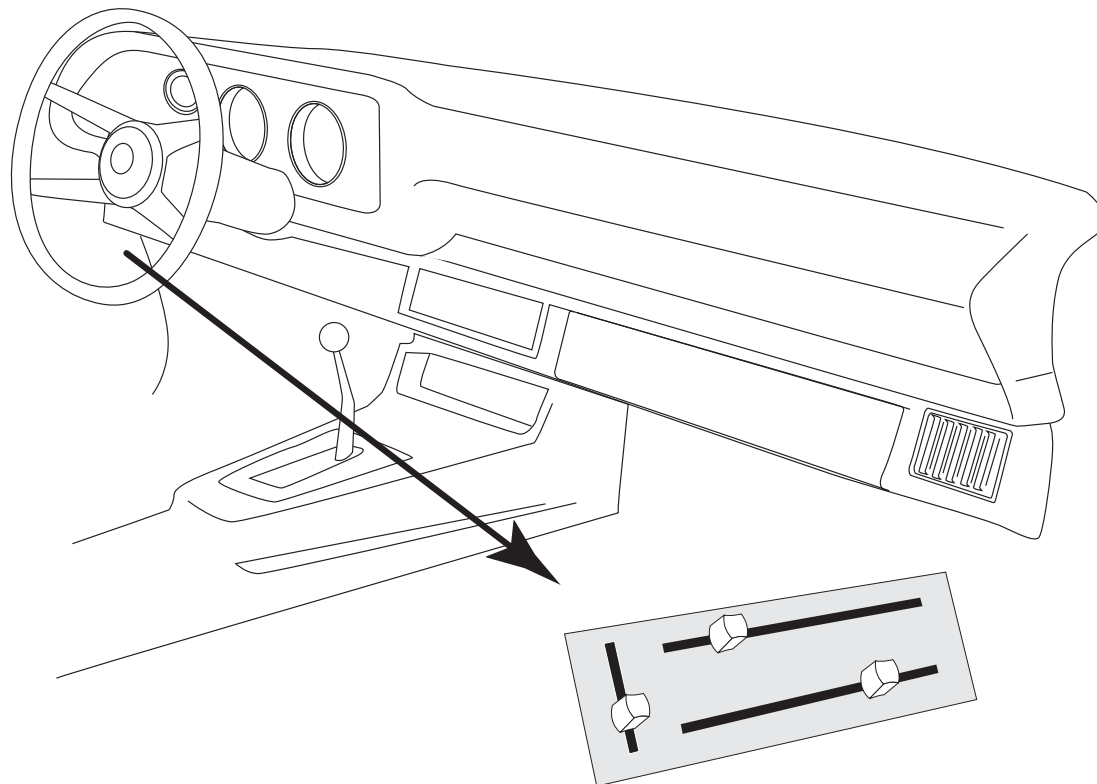

FIGURE 5

Moving to the engine compartment:

In order to remove your heater assembly it is necessary to remove the heater case housing first.

Located on the engine side of the firewall, remove seven (7) bolts around the perimeter of the heater case housing (see Figure 7). Remove the housing (Discard).

**NOTE:** To remove the two bolts at locations 1A and 7B, it may be necessary to lower the inner fender. Retain these screws.

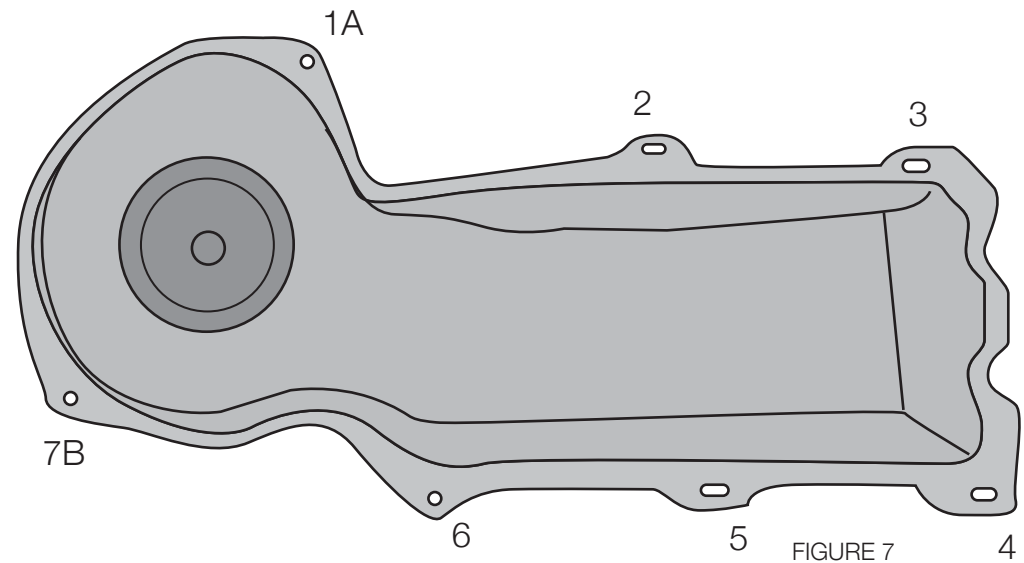

Drain coolant from radiator. Remove the heater hoses from heater coil and firewall (see Figure 8).

You will also cut a power lead to the blower motor. This will not be re-used.

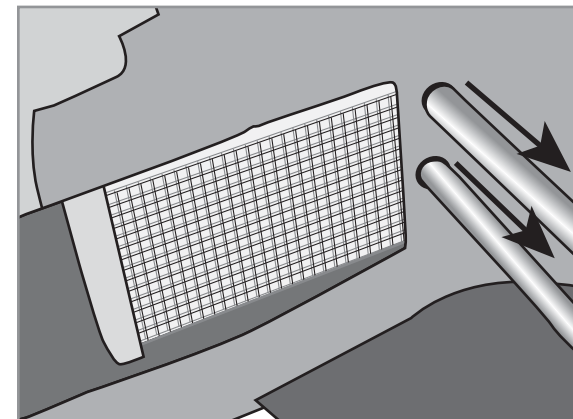
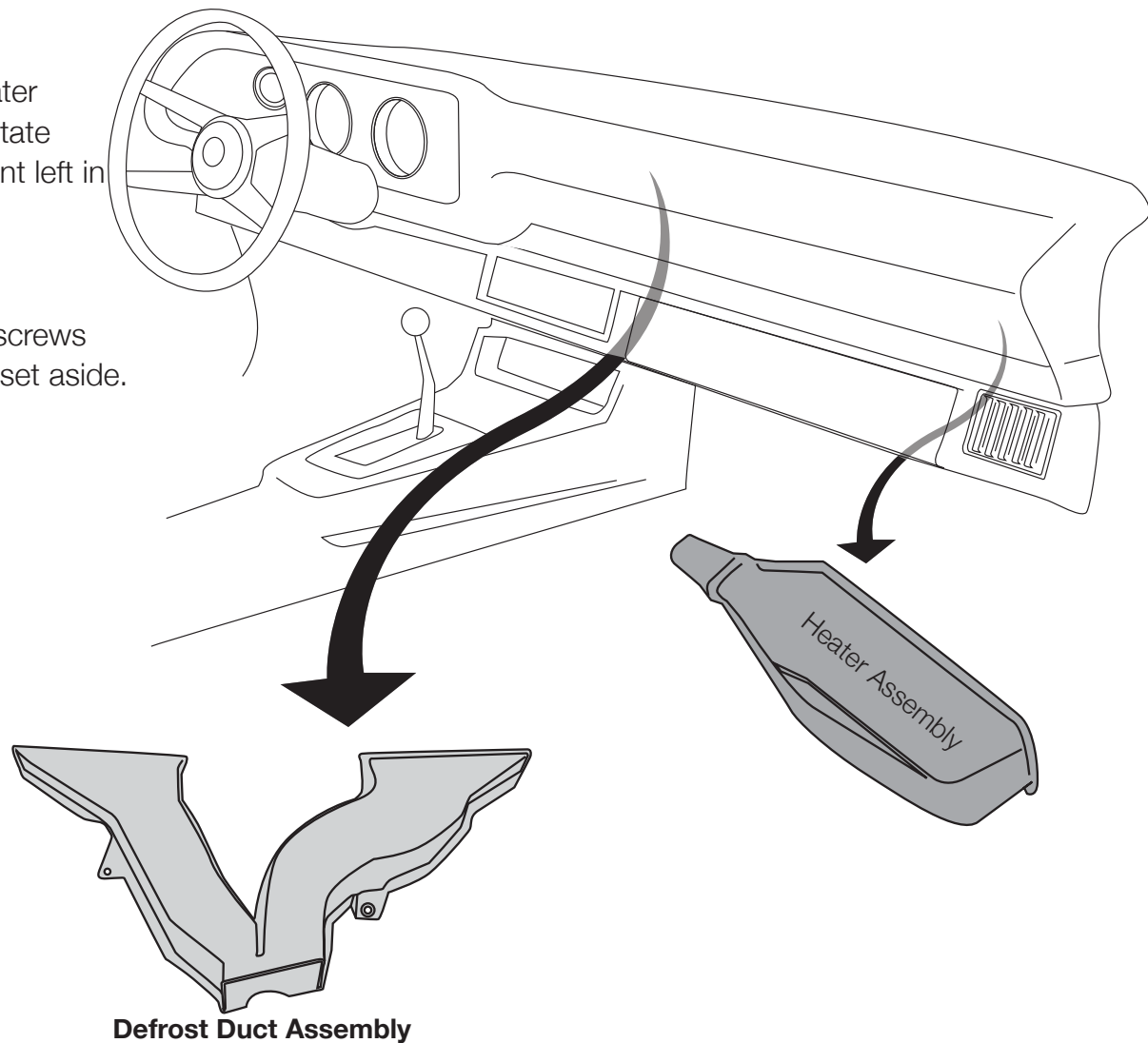

FIGURE 8

You should now be able to remove the heater assembly located behind the dash area. Rotate upward being careful not to drain any coolant left in the heater coil.

The OEM defrost duct is secured with two screws. Remove both screws from the defrost duct and set aside.



## THESE ARE THE PARTS YOU WILL FIND IN CONTROL BOX

You will use all of these parts and hardware during the next series of installation steps.

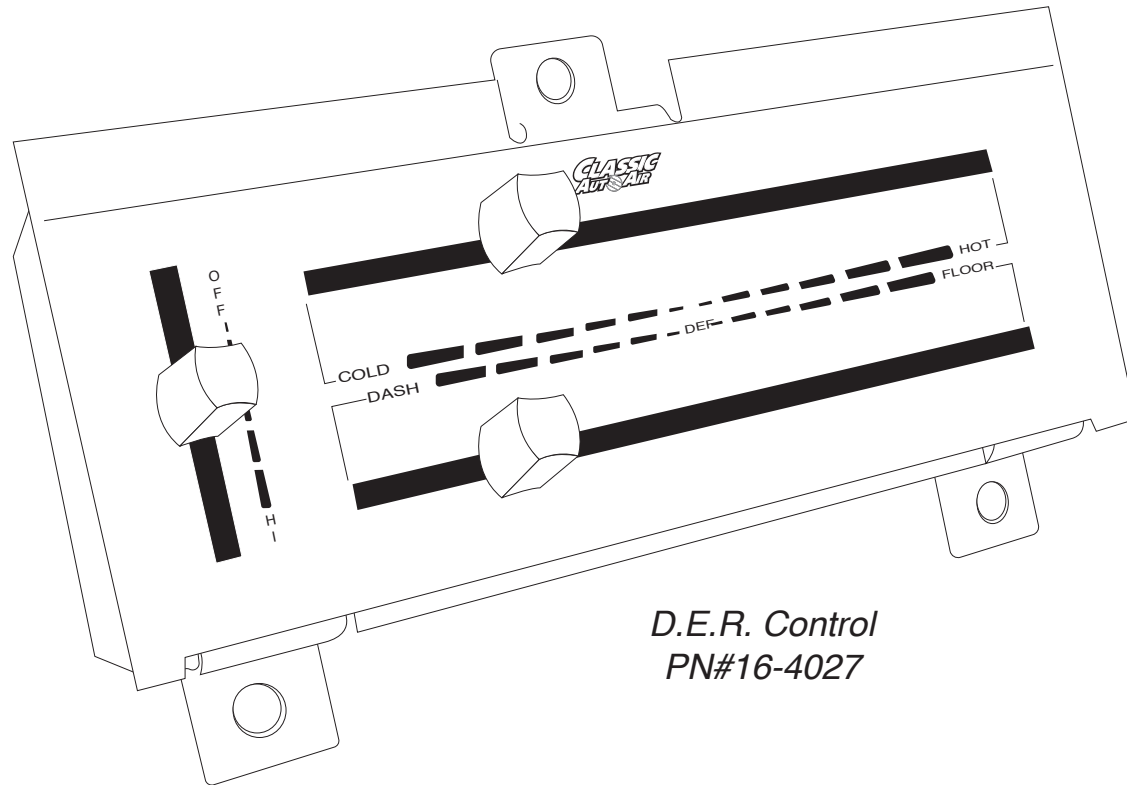

*D.E.R. Control  
PN#16-4027*

## THESE ARE THE PARTS YOU WILL FIND IN BAG KIT B

You will use all of these parts and hardware during the next series of installation steps.

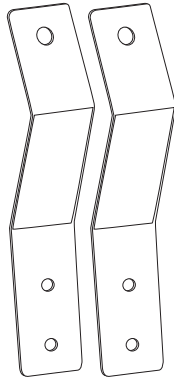

Evaporator Support Brackets  
PN#0023-7

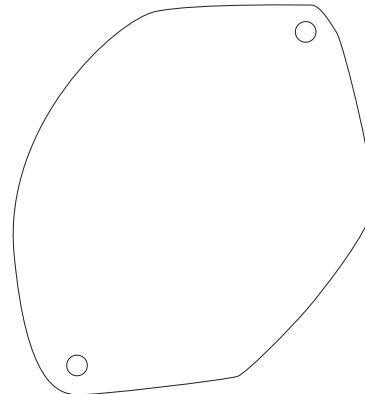

Fresh Air Inlet Block Off  
PN#10-1048-2

Liquid Tube  
PN#0034-9

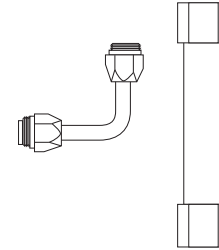

Suction Tube  
PN#0034-10

○ ○ #6 and #10 O-ring

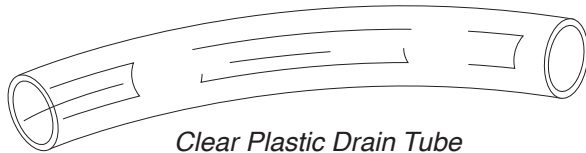

Clear Plastic Drain Tube

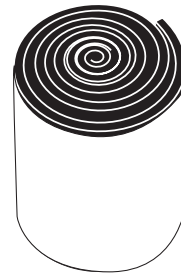

Refrigerant Tape

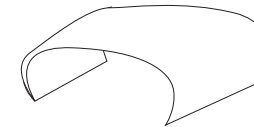

One Bulb Clamp

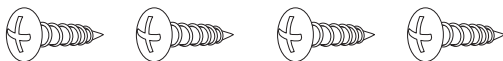

Four #10 - 10 x 5/8" Phillips Screws

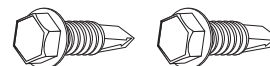

Two #10 - 16 x 3/4" Tek Screws



One Flange Nut

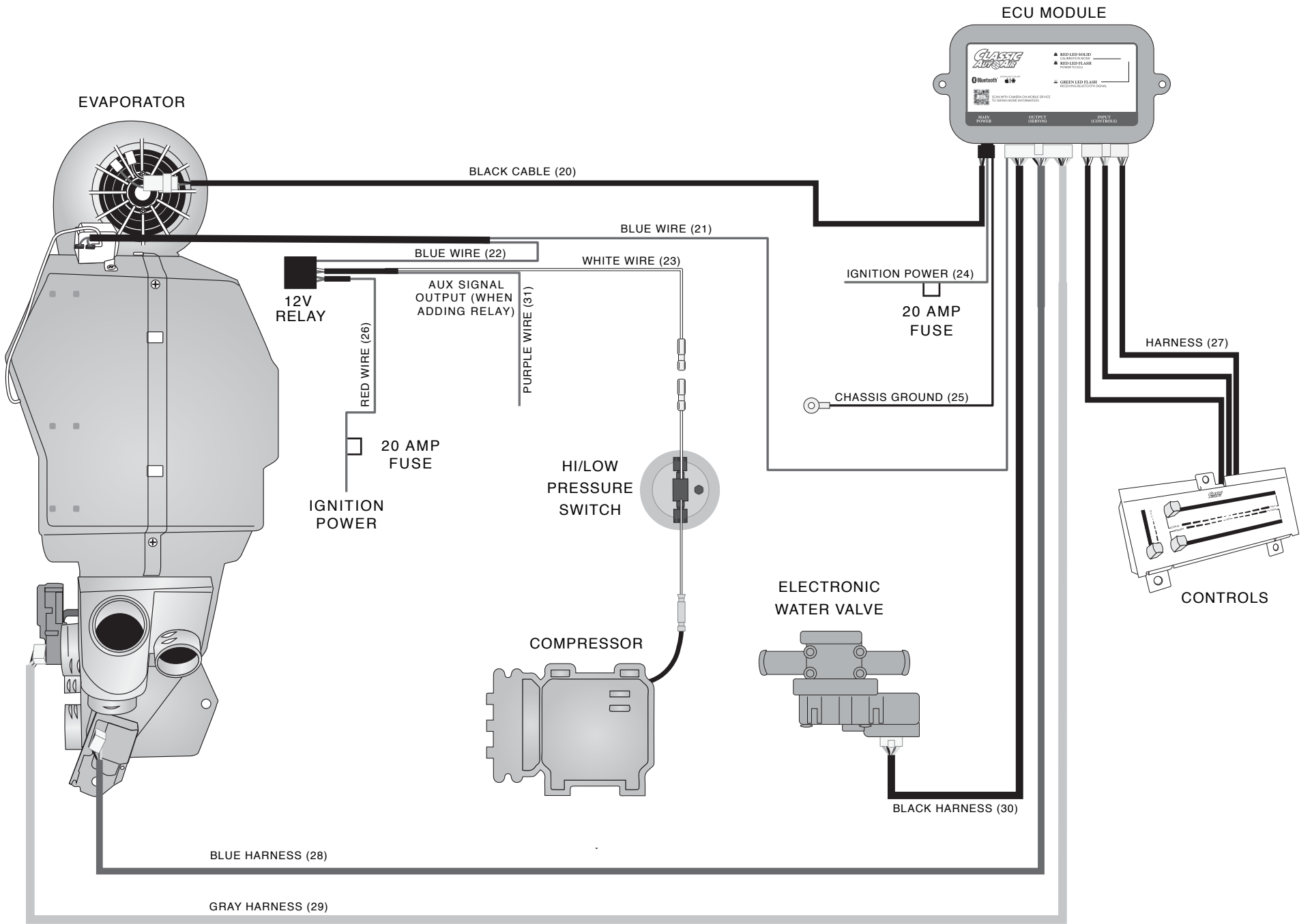

Within the engine compartment area, Install Fresh Air inlet block-off PN# 10-1048-2 (from Bag Kit B) over the OEM fan opening using the OEM screws (A1 and B7).

If necessary, reinstall inner fender.

Remove evaporator unit from box and place on a work surface.

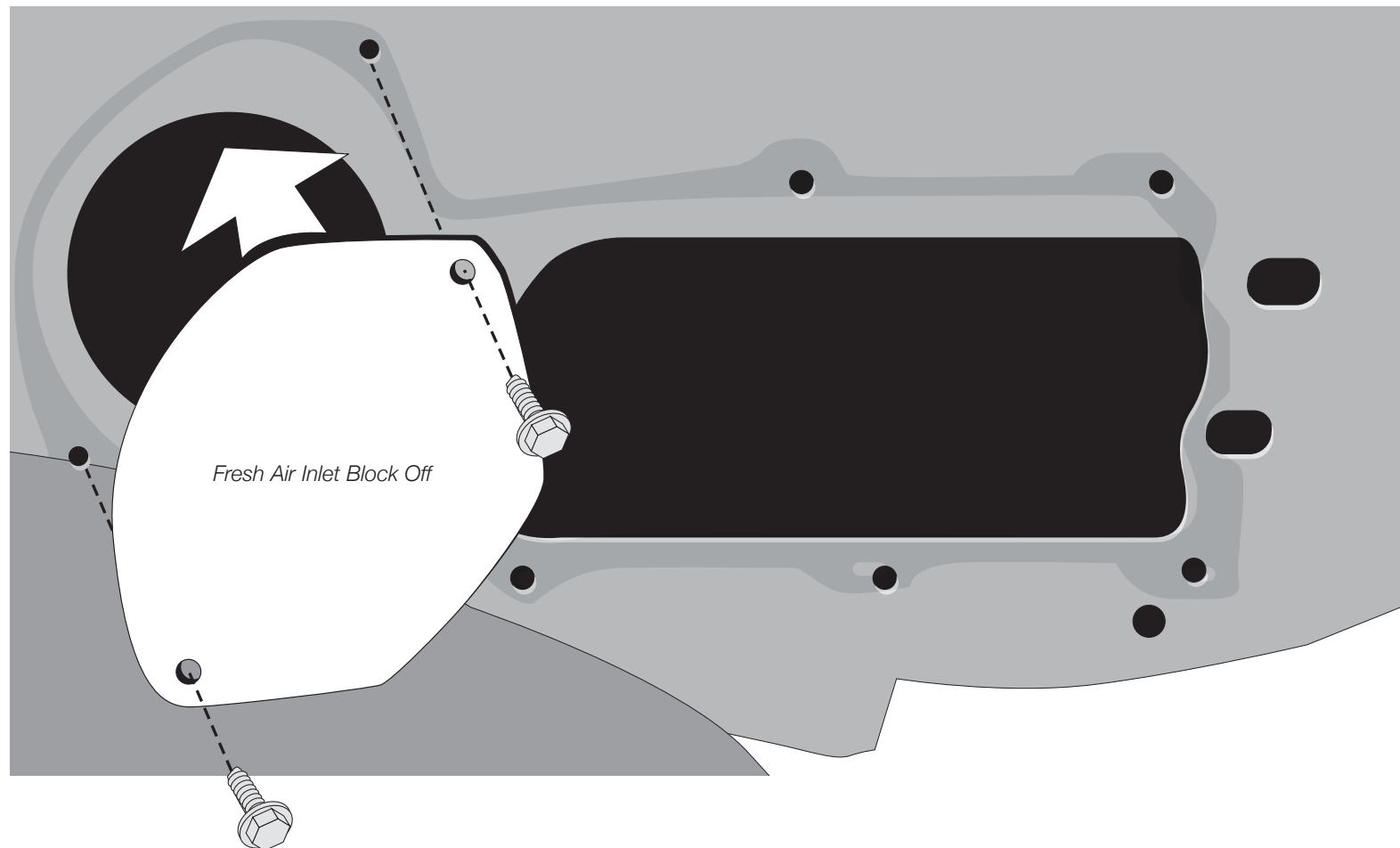

# OPERATIONS

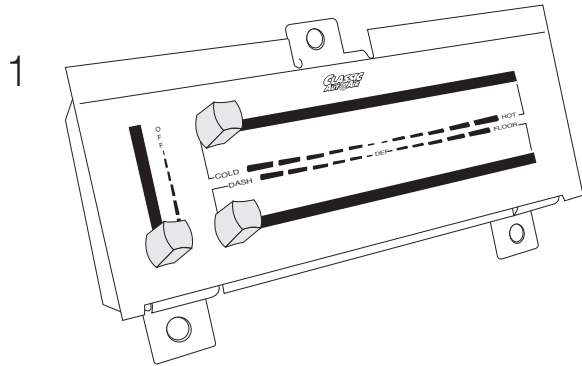

Move FAN knob to HIGH  
Move MODE knob to DASH  
Move TEMP knob to COLD



AIR OUT OF DASH VENTS

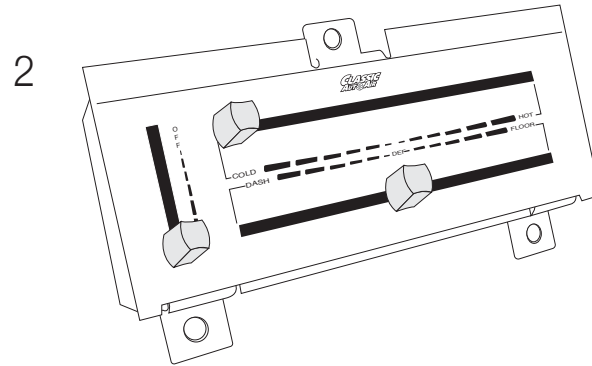
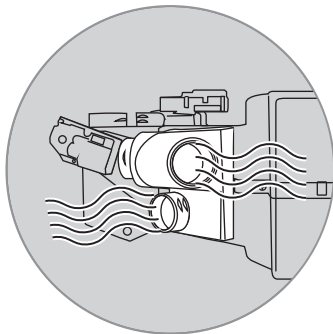

Move MODE knob to DEF



AIR OUT OF DEFROST VENTS

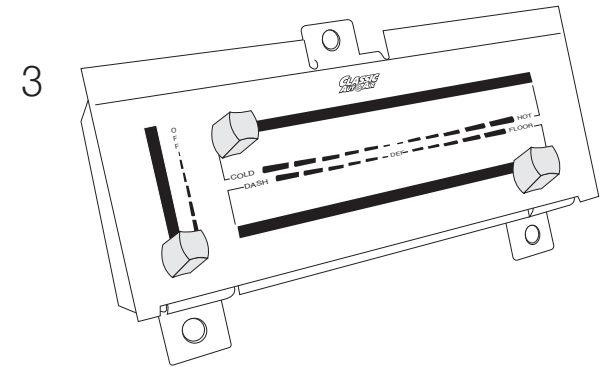
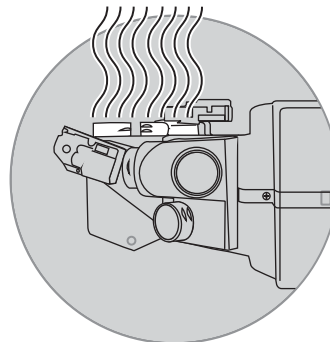

Move MODE knob to FLOOR



AIR OUT OF FLOOR VENTS

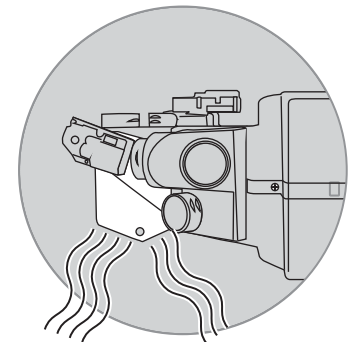



# OPERATIONS

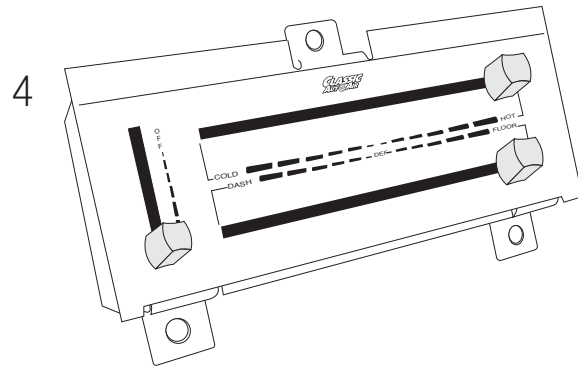

Move TEMP knob to HOT

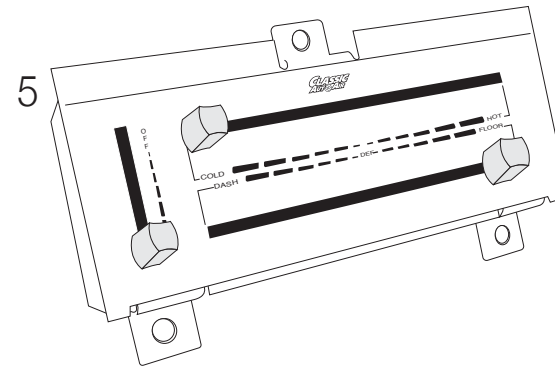

Move TEMP knob to COLD

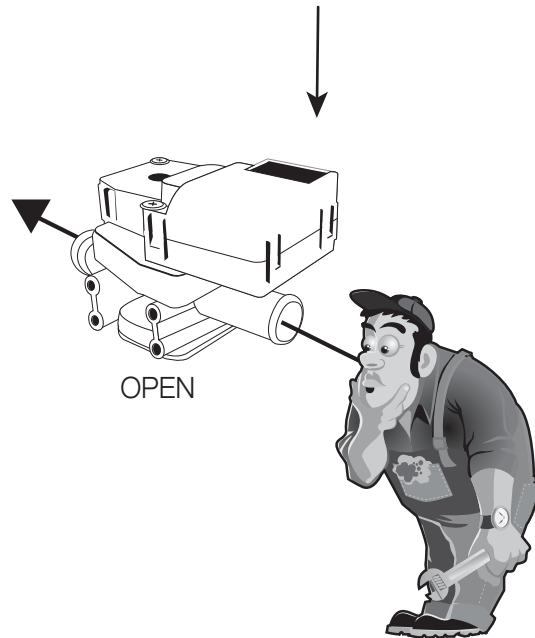

You will be able to see through water valve passage

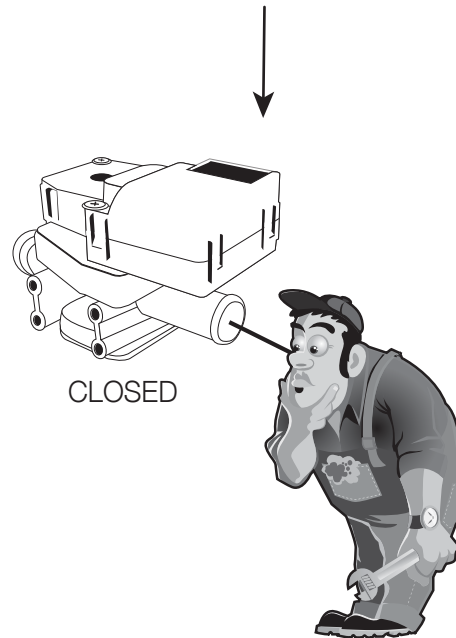

You will NOT be able to see through water valve passage

Return all wiring harnesses, water valve, and ECU to their originally bags/boxes (this keeps them organized for future installation steps).

Your controls are now fully calibrated to your unit. Please refer to the next steps in your installation manual for installing the system in your vehicle.

NOTE: IF DURING ANY OF THESE STEPS YOU DO NOT GET THE CORRECT OUTCOME, PLEASE CALL TECH SUPPORT BEFORE INSTALLING INTO VEHICLE.  
1(866)435-7801

**NOTE: Two people are needed for this step!**

Place evaporator on floor panel. Roll unit up behind the glove box opening, inserting tubes through the large hole in firewall.

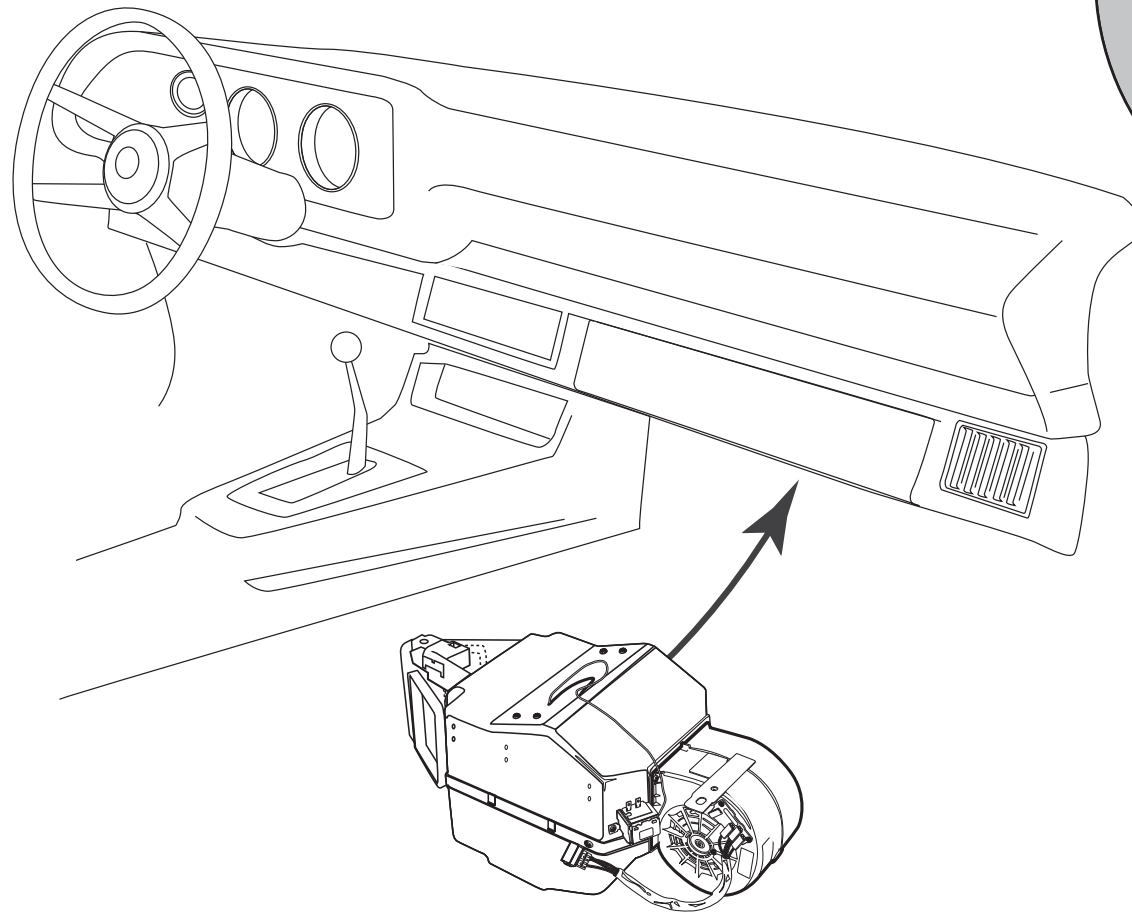

1

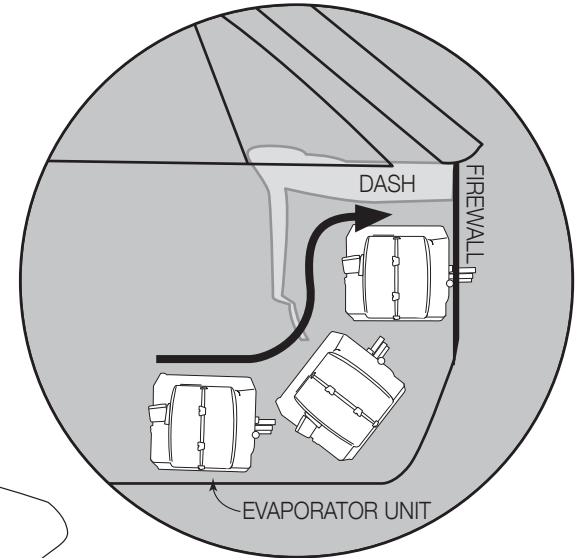

Installing the complete evaporator unit under the dash will go much easier with the help of a friend. Once the unit has been rolled up under the dash, one person can hold the unit in place while the other person can be ready at the firewall area with the included flange nut to secure the unit (see figure 17). Leave Flange nut loose to allow leveling of unit in next steps.

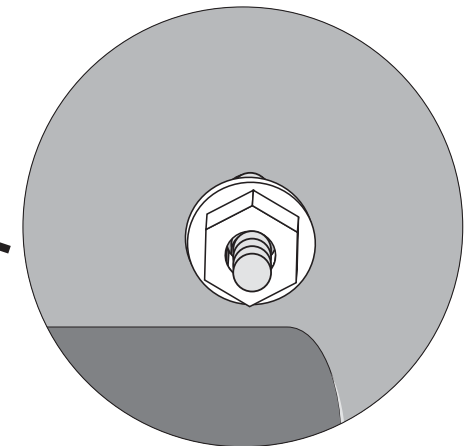
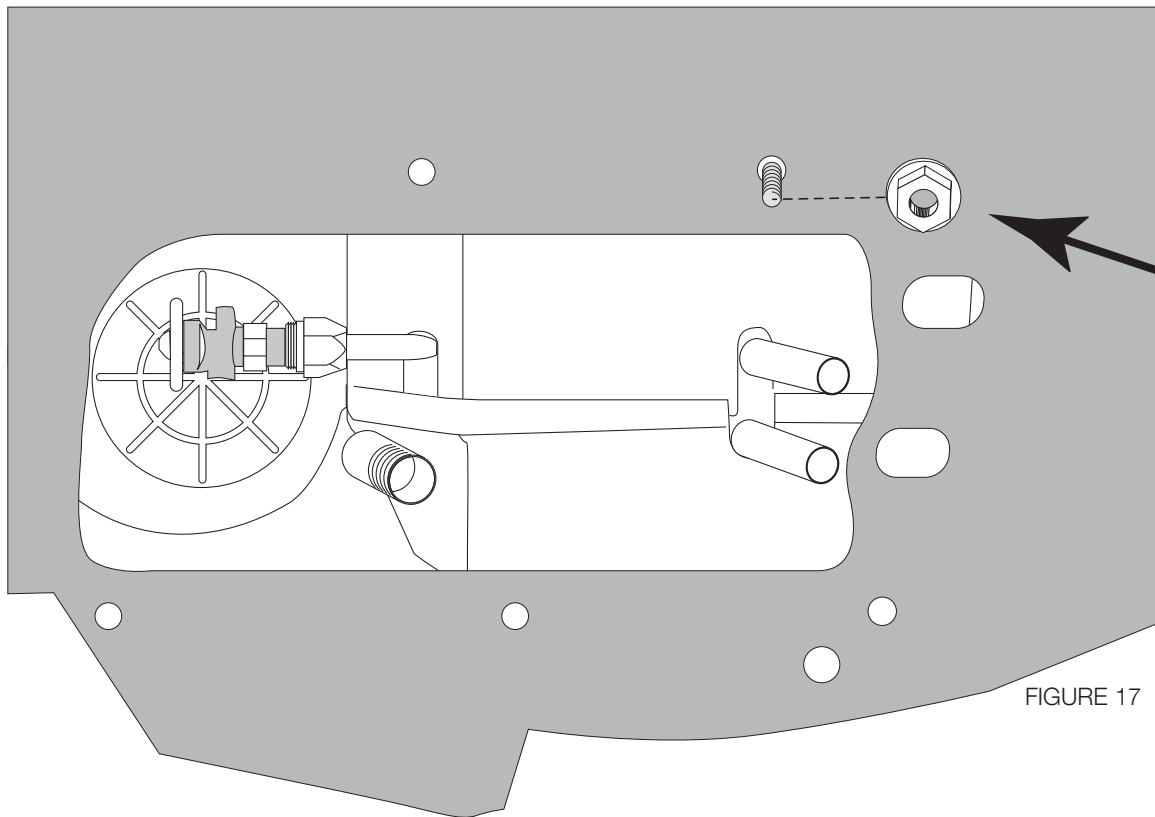
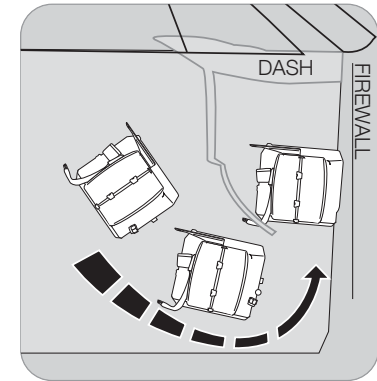
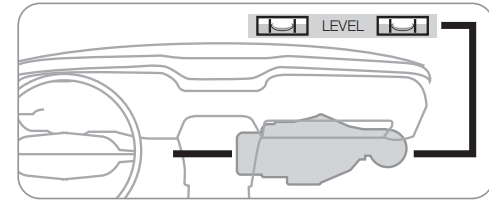

FIGURE 17

Locate the UPPER MOUNTING BRACKETS and attach to evaporator unit using four #10 - 10 x 5/8" Phillips screws. Attach other end to the cowling with a #10 - 16 x 3/4" Tek Screw (see figure 9).

**IMPORTANT NOTE:** On the side of the main unit you will see several holes for mounting holes... **ONLY USE THE ONES ON THE FAR LEFT AND RIGHT FOR THESE BRACKETS!** Do not tap into the other holes for any reason (see figure 10). Also, use a screwdriver and hand-power and do not over-tighten so you don't strip the holes.



Be sure to align the evaporator unit level with the bottom of dash as shown above, with a small degree of tilt toward the back to allow proper drain of condensation.

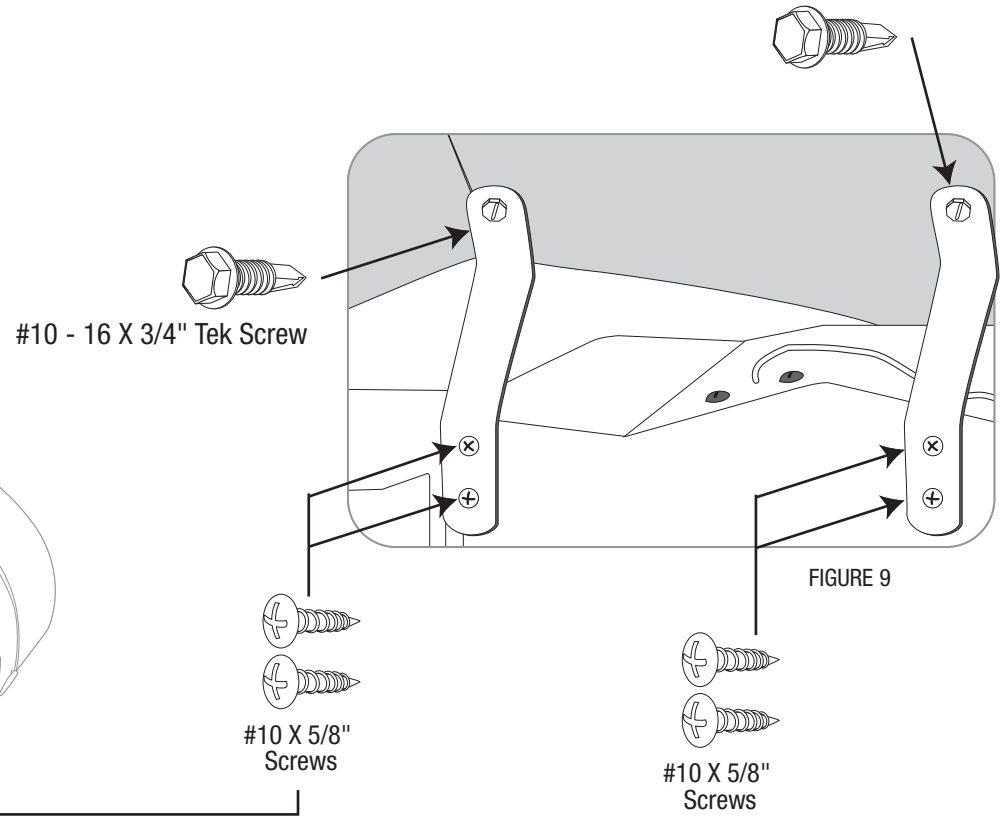
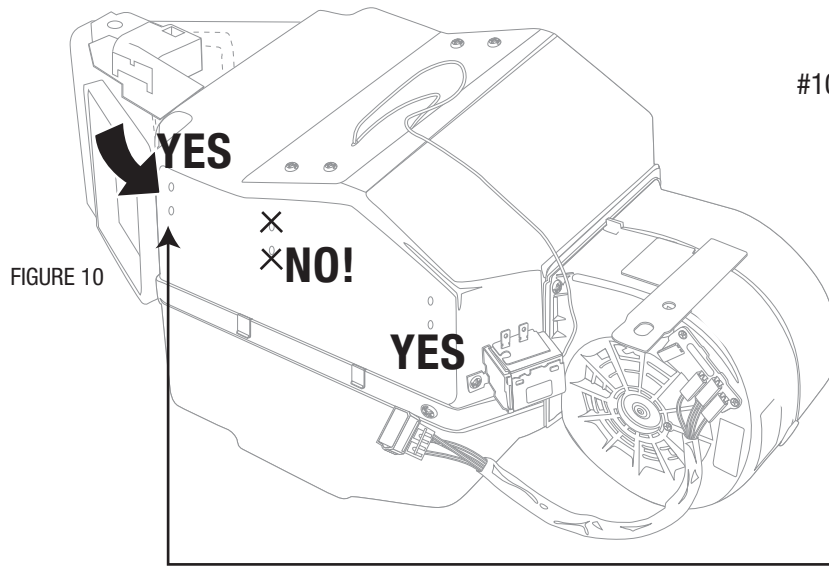

Install liquid line onto the Expansion valve (TXV) as shown. Use #6 o-ring and (2) drops of mineral oil on the o-ring and tighten securely.

Install Suction Tube to the outlet on the unit as shown. Use #10 o-ring and (2) drops of mineral oil on the o-ring and tighten securely.

Locate Sensing Coil attached to Expansion valve (TXV) and utilizing Bulb Clamp, attach to the Suction Tube.

**CAUTION: THE SYSTEM WILL NOT FUNCTION PROPERLY IF THE SENSING COIL IS NOT CLAMPED IN THE CORRECT POSITION. SEE PICTURE.**

Wrap Suction Tube and Sensing Coil with the refrigerant tape provided. Be sure that all of the exposed metal is covered.

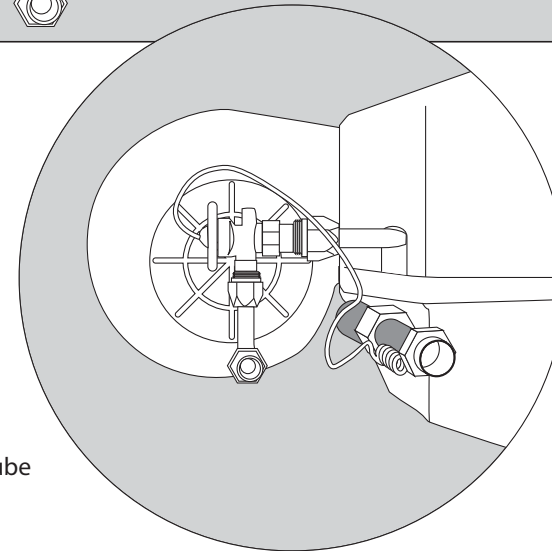
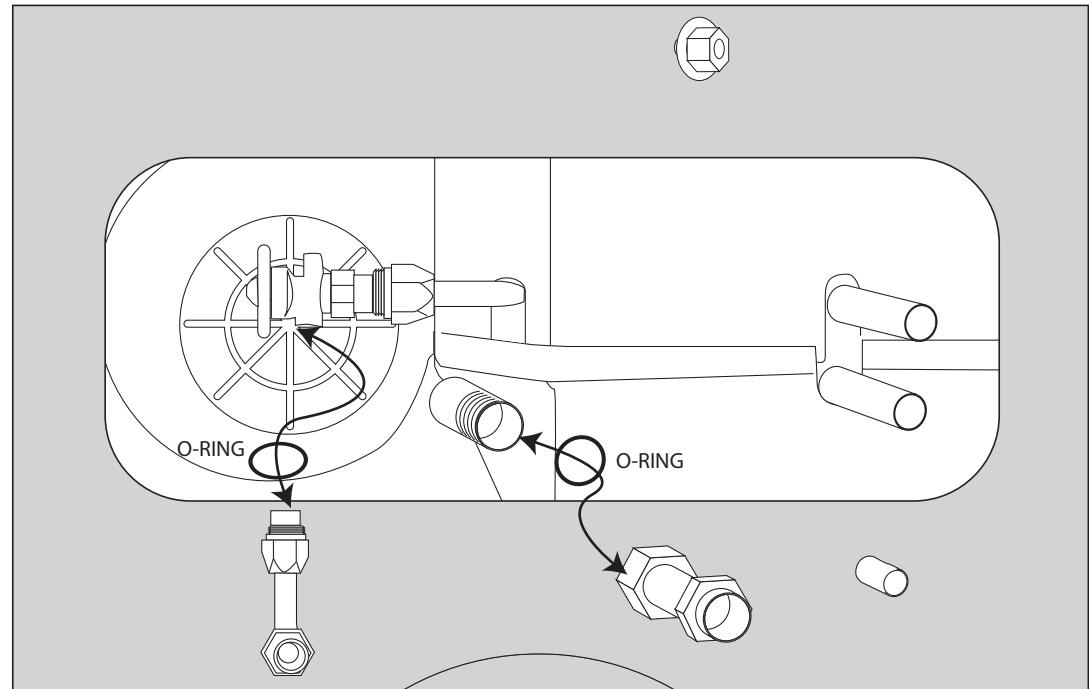

**Reminder...**  
Use two  
wrenches to  
tighten o-ring  
fittings

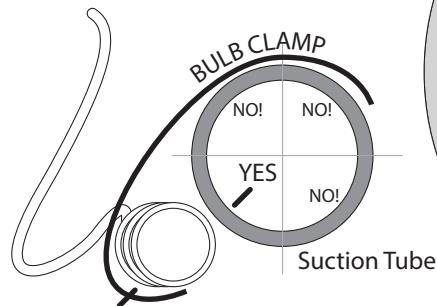

## Installing the Drain tube



THIS IS FROM INSIDE THE VEHICLE!

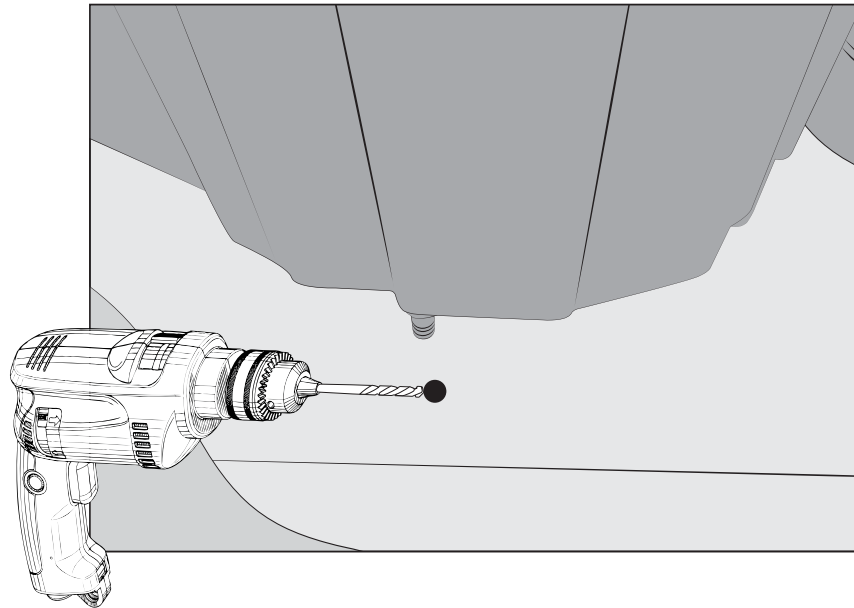

Locate Drain nipple on Evaporator and drill a 3/4" hole below the nipple on the firewall. This will allow condensation to drain properly.

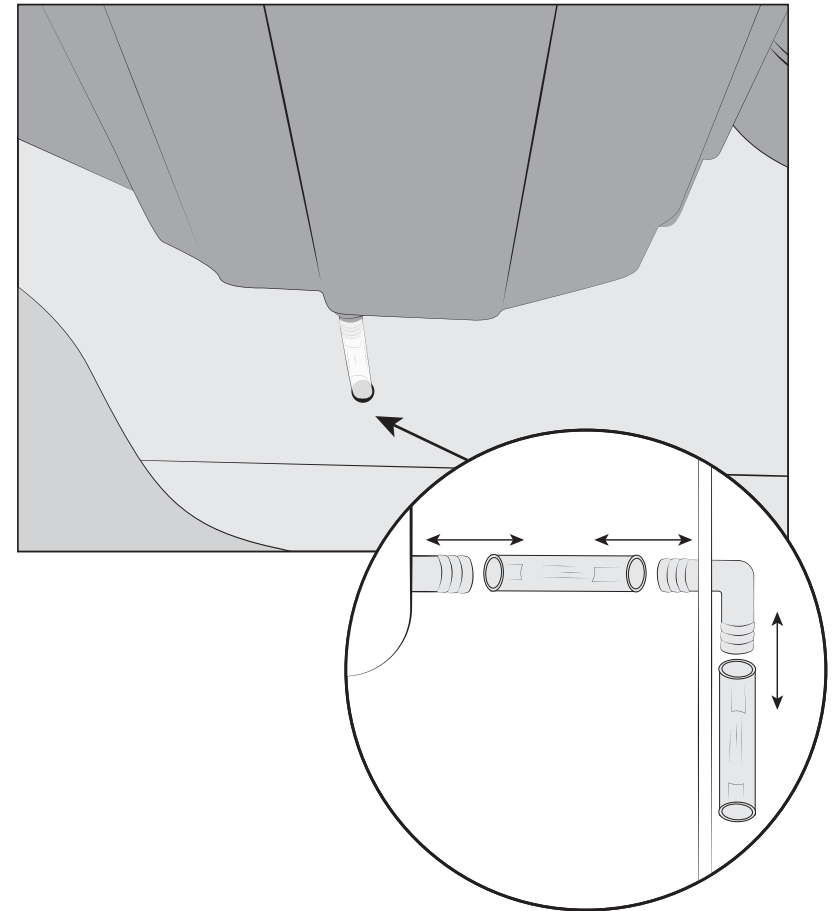

Attach 1/2" clear drain tube to Evaporator nipple and run through 3/4" hole you just drilled.

All condensation will now drain out into the engine bay.

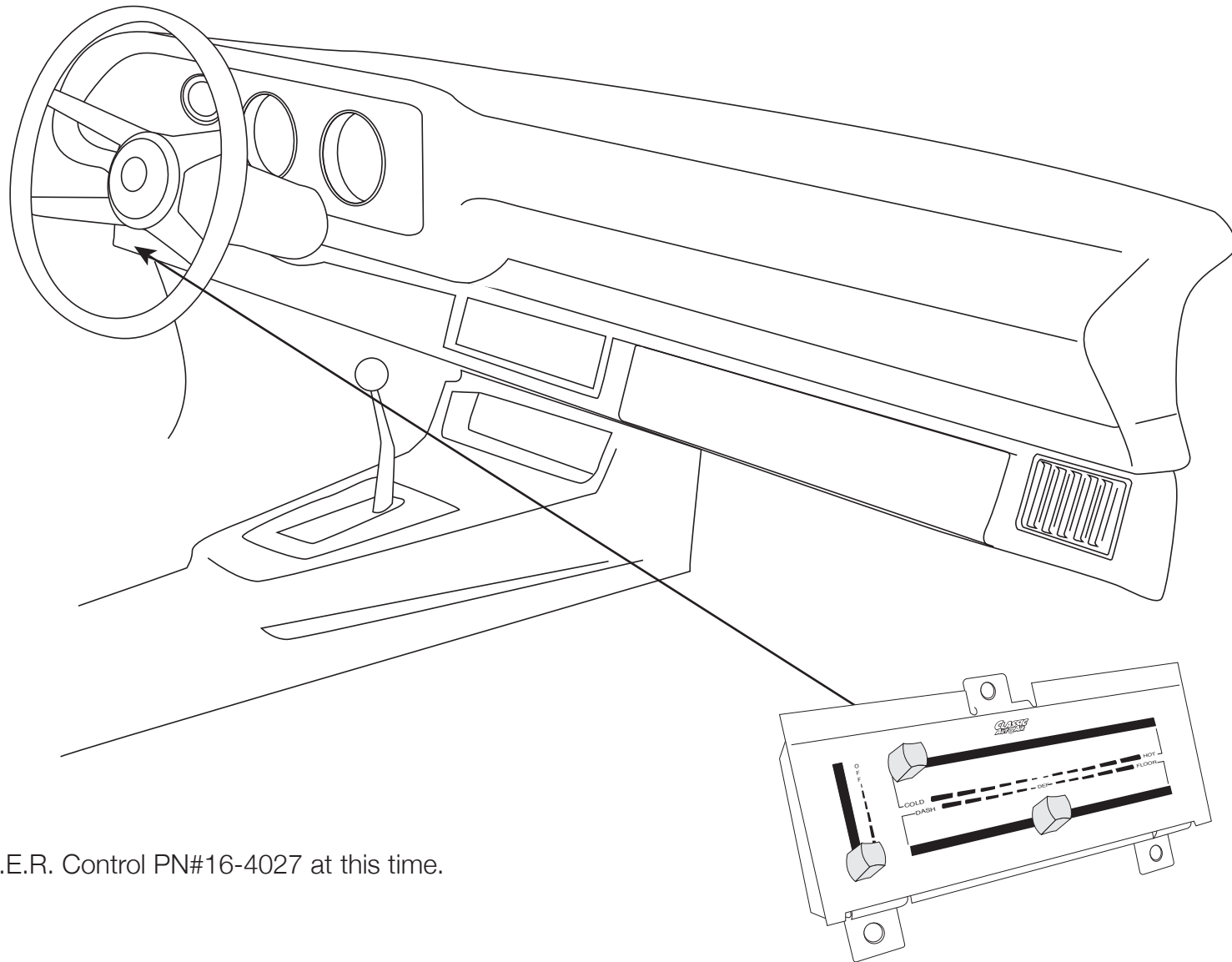

Install D.E.R. Control PN#16-4027 at this time.

# THESE ARE THE PARTS YOU WILL FIND IN BAG KIT C

You will use all of these parts and hardware during the next series of installation steps.

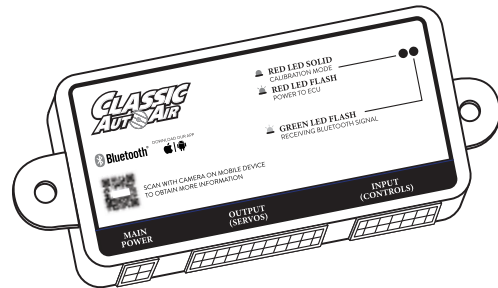

ECU  
16-2500

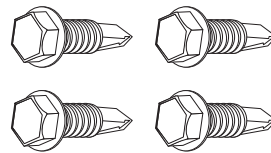

Four #10 - 16 x 3/4" Tek Screws

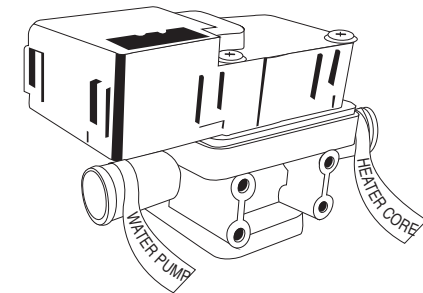

Electronic Water Control Valve  
PN# 16-1023

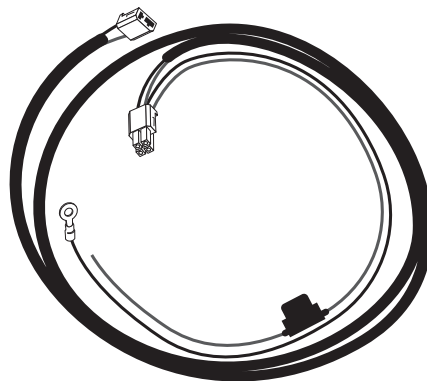

HARNESS POWER SUPPLY  
0125-5



Relay  
30-13373

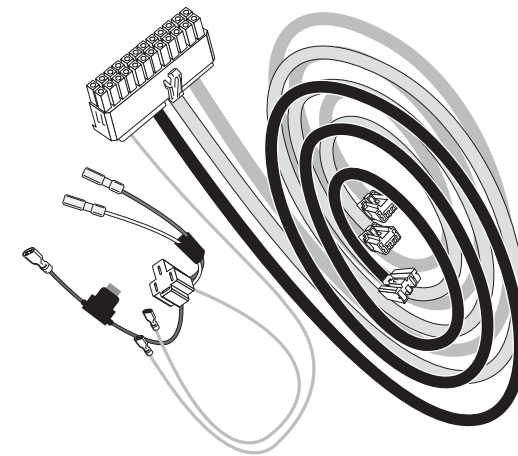

HARNESS  
0125-6A



## THESE ARE THE PARTS YOU WILL FIND IN BAG KIT D

You will use all of these parts and hardware during the next series of installation steps.

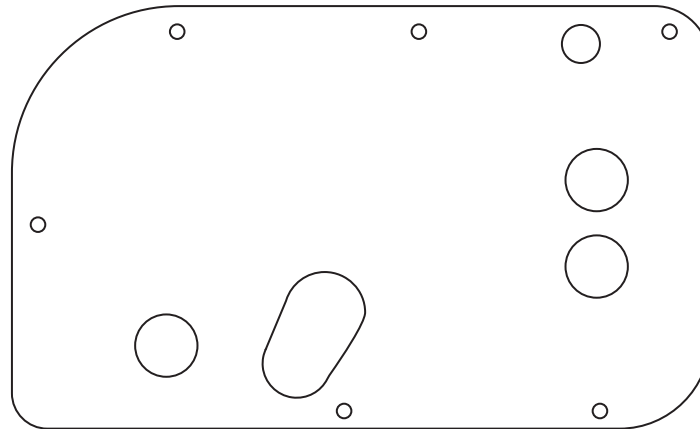

*Firewall Block Off  
PN#10-1049-1*

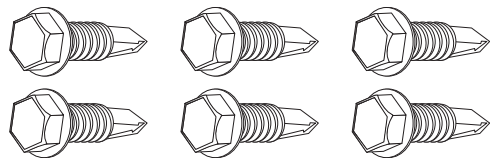

*Six #10 - 16 x 3/4" Tek Screws*

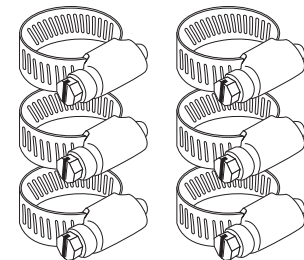

*Six Worm Gear Clamps*

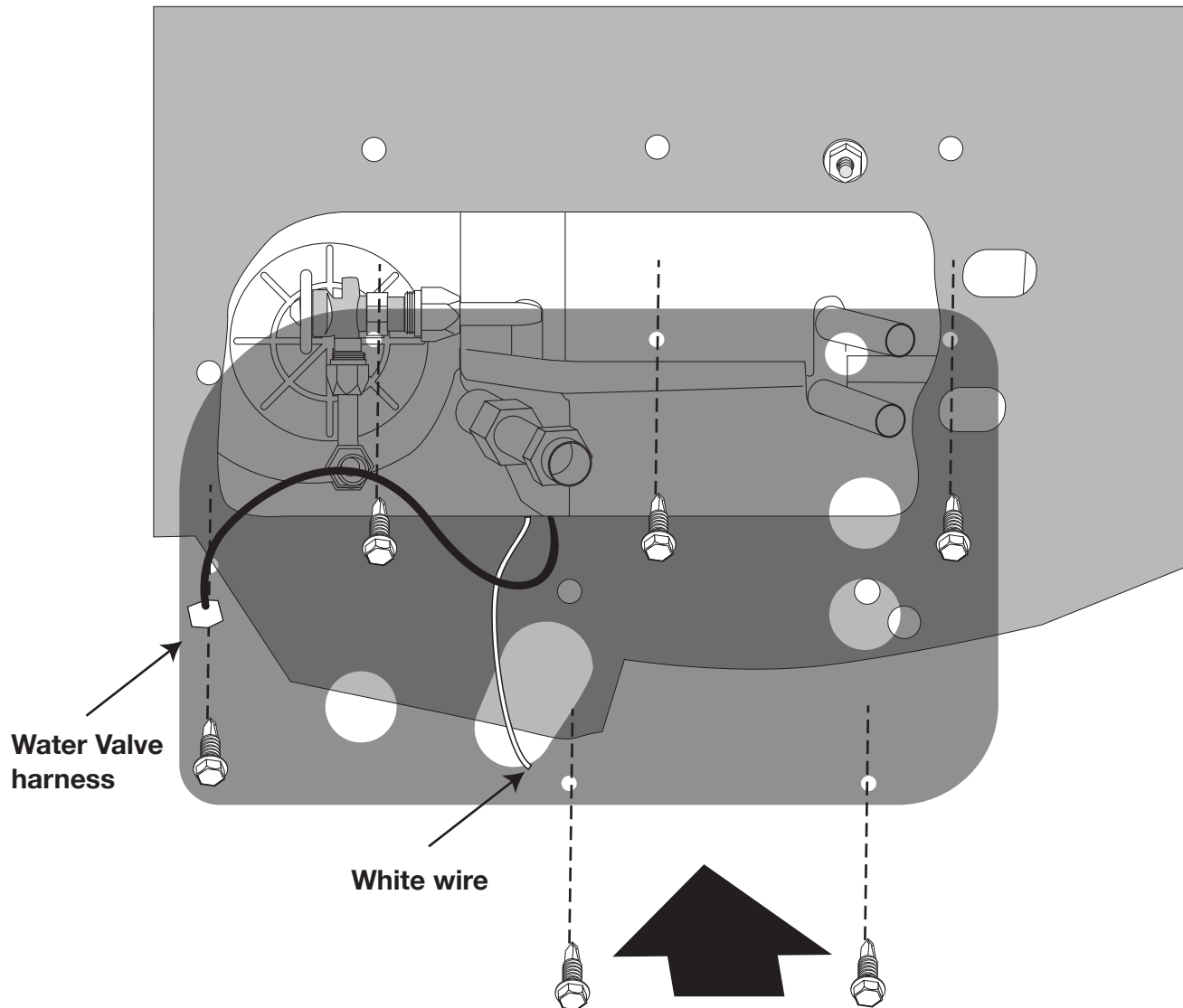

In **Bag Kit D** you'll find the firewall block off. Install this over the hose connections coming through the firewall within the engine compartment. Attach with six #10 - 16 x 3/4" Tek screws.

**TIP: Route Water Valve cable through the block off plate.**

The loose white wire from main power harness can be fed through the same hole (as shown below).

**IMPORTANT NOTICE: PROPER  
INSTALLATION OF WATER VALVE**

**Your water valve MUST be installed per these instructions!... (If not, your system will not work properly.**

The **lower** heater tube connection on firewall will be routed to the water connection on intake manifold using 5/8" dia. heater hose with the supplied worm gear clamp.

The **upper** heater tube connection on the firewall will be routed to the water valve connection labeled **heater core**, using a 6" piece of 5/8" heater hose attached with supplied worm gear clamp.

Connect the remaining outlet on water valve labeled **water pump** to the water pump using 5/8" dia. heater hose with the supplied worm gear clamp.

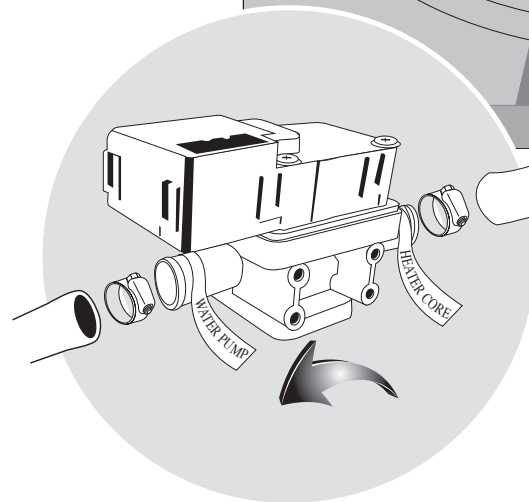
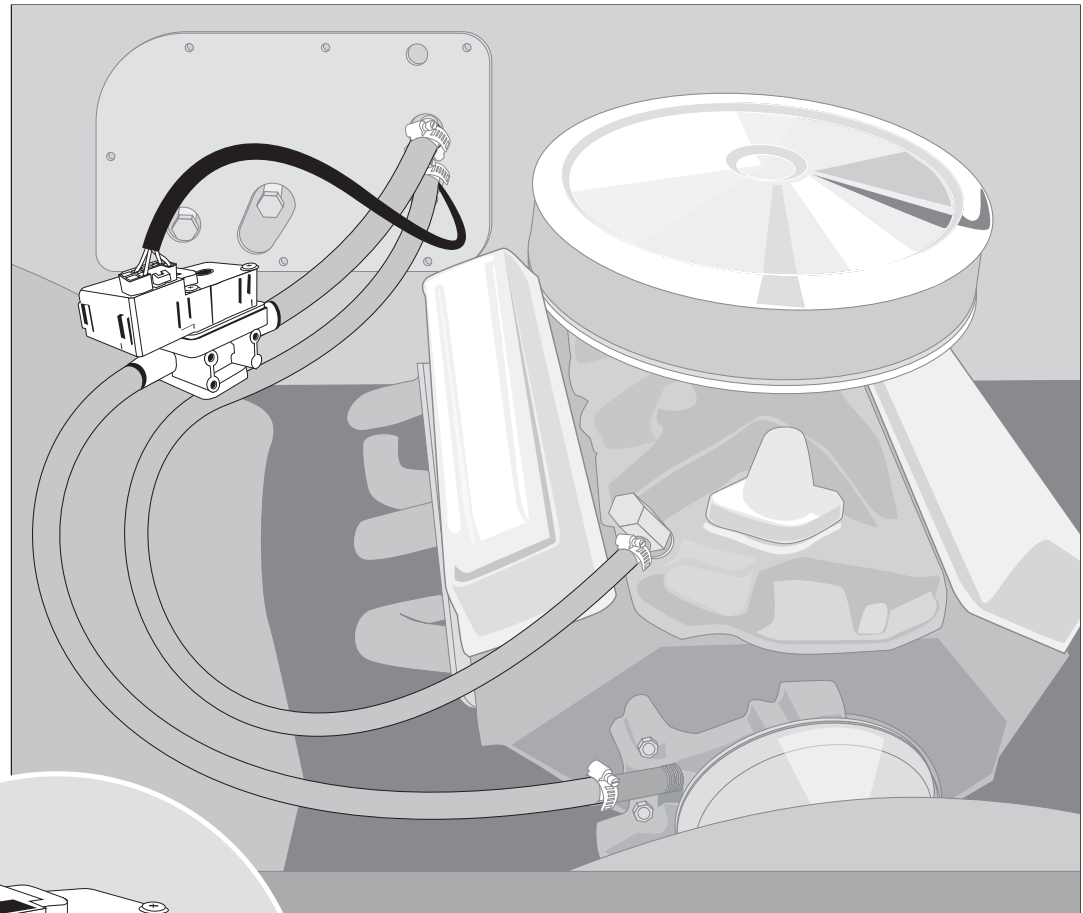

**FOLLOW THESE  
TAGS... CHECK IT  
TWICE BEFORE  
PROCEEDING!**

# THESE ARE THE PARTS YOU WILL FIND IN BAG KITS E, F, and G

You will use all of these parts and hardware during the next series of installation steps.

## Bag E

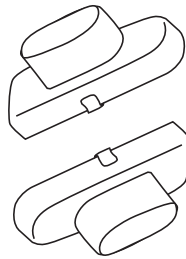

*Drivers-side Defrost Adapter  
PN#2-1057-3*

*Passenger-side Defrost Adapter  
PN#2-1057-4*

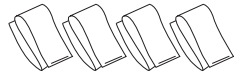

*Four S-Clips*

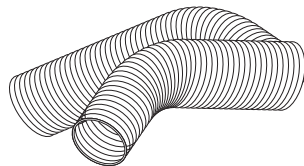

*Two Duct Hoses, 2" I.D.*



*Four Zip-Ties*

## Bag F

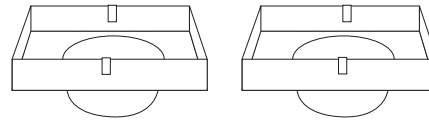

*Two Louver Adapters  
PN#2-1057-2*

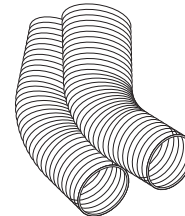

*Two Duct Hoses, 2" I.D.*

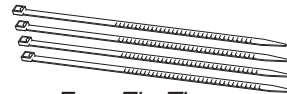

*Four Zip-Ties*

## Bag G

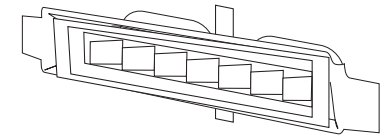

*Center Dash Vent Adapter  
PN# 2-1057-1*

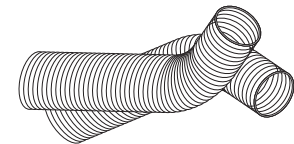

*Two Duct Hoses, 2" I.D.*



*Four Zip-Ties*

Before you install the evaporator, the OEM defroster duct must be removed and modified.

- 1) Detach the entire assembly and place on a flat work surface.
- 2) Detach the left and right upper ducts. Cut out and attach the included templates and trim as indicated.
- 3) Attach the defrost adapters (S-clips on adapters will hold firmly).
- 4) Place the included S-clips over the leading edge of the OEM defroster ducts, and set aside for later installation.

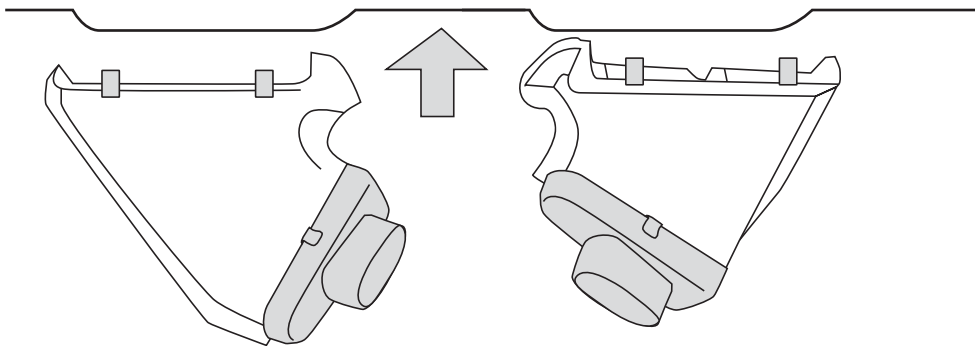
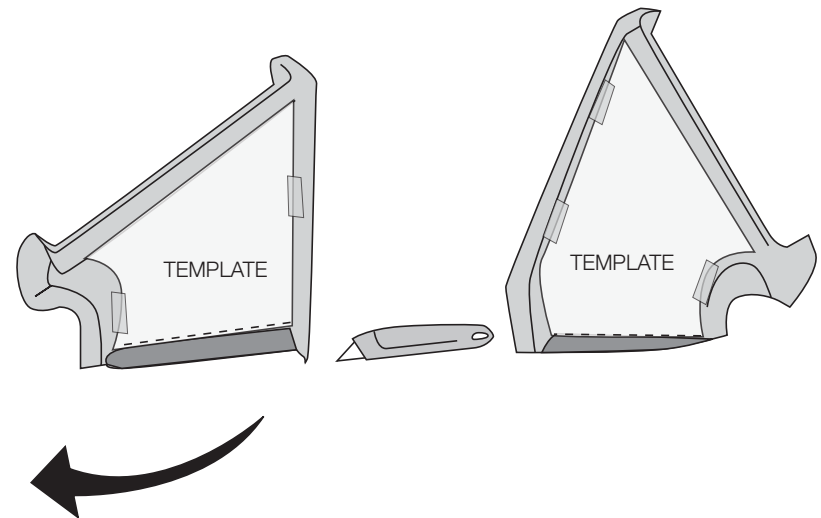
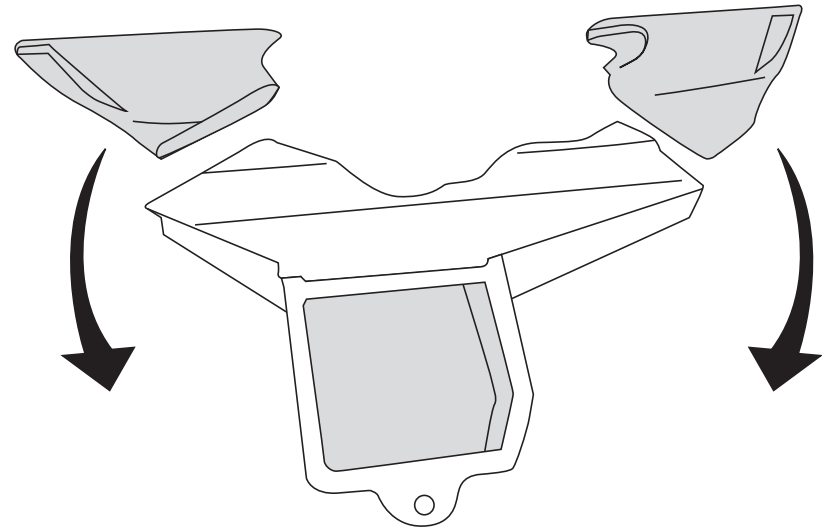

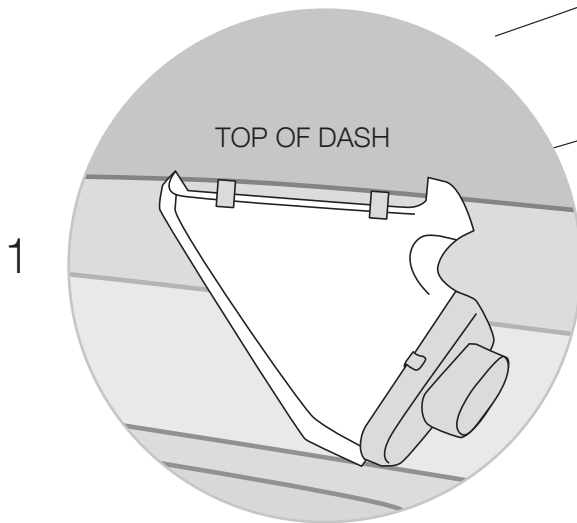
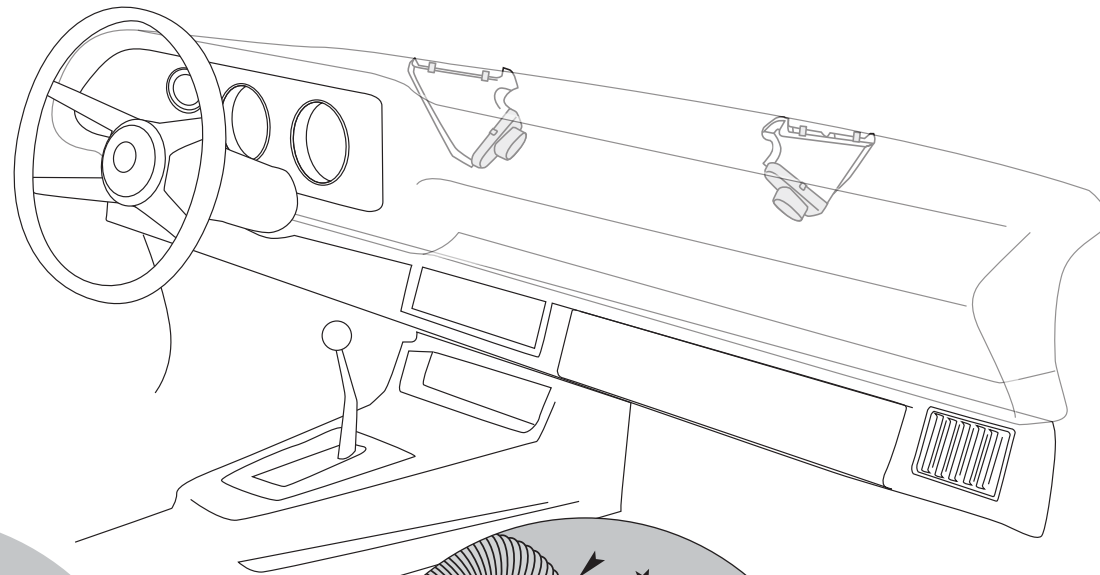

Push defrost vent assy onto lip of dash tab (below defrost vents, inside of dash), S-clips (already installed) will hold the adapters securely

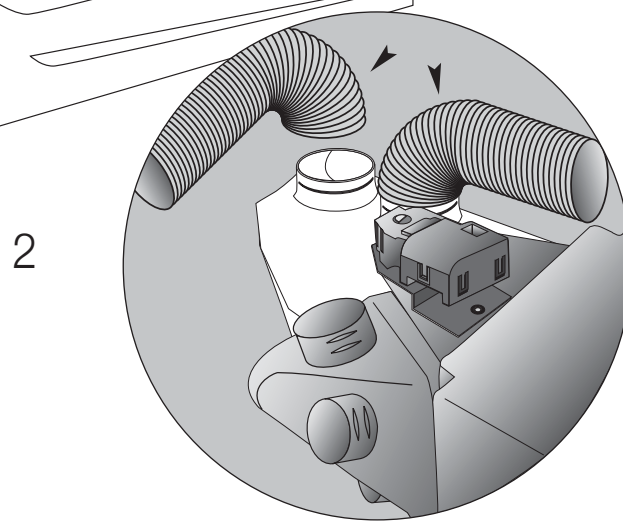

One end of the duct hose is installed over the defrost/heat duct assembly outlets on the main unit.

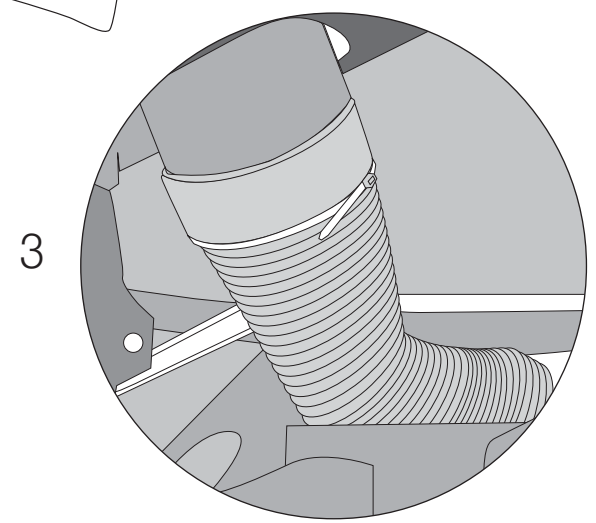

Next route the duct hoses from the defrost/heat duct assembly upward toward defrost vents. Attach the flex hose to the defrost diffuser using zip-ties on both ends.

**Bag Kit G:** Installing the center louver vent requires a small amount of cutting to the dash support. Locate template for the center dash louver installation and tape it to the dash pad. Bottom edge of template aligns with the edge of dash pad.

Cut a hole thru the dash pad.

Your new center louver came with an adapter and a brace, already assembled. Remove the brace temporarily, place louver and adapter into hole, then secure both to dash (from the backside) with the brace and screw we provided.

Route supplied flex hose from the center louver outlets on the dash duct assembly. Secure with zip-ties at both ends.

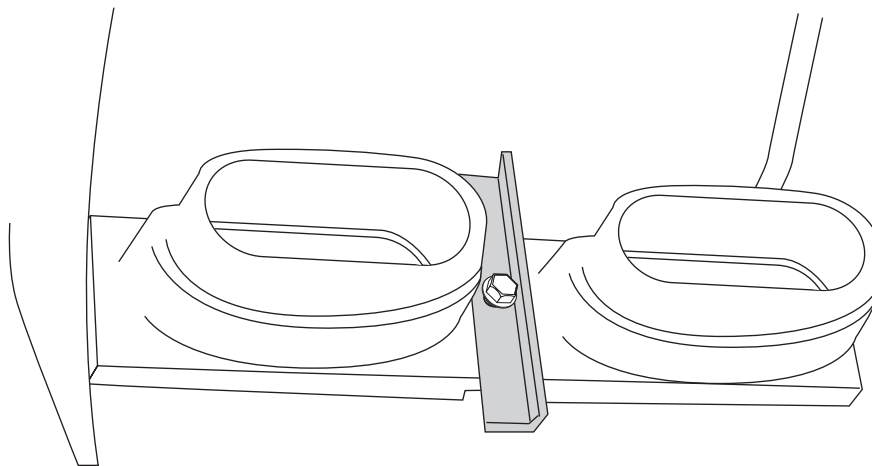
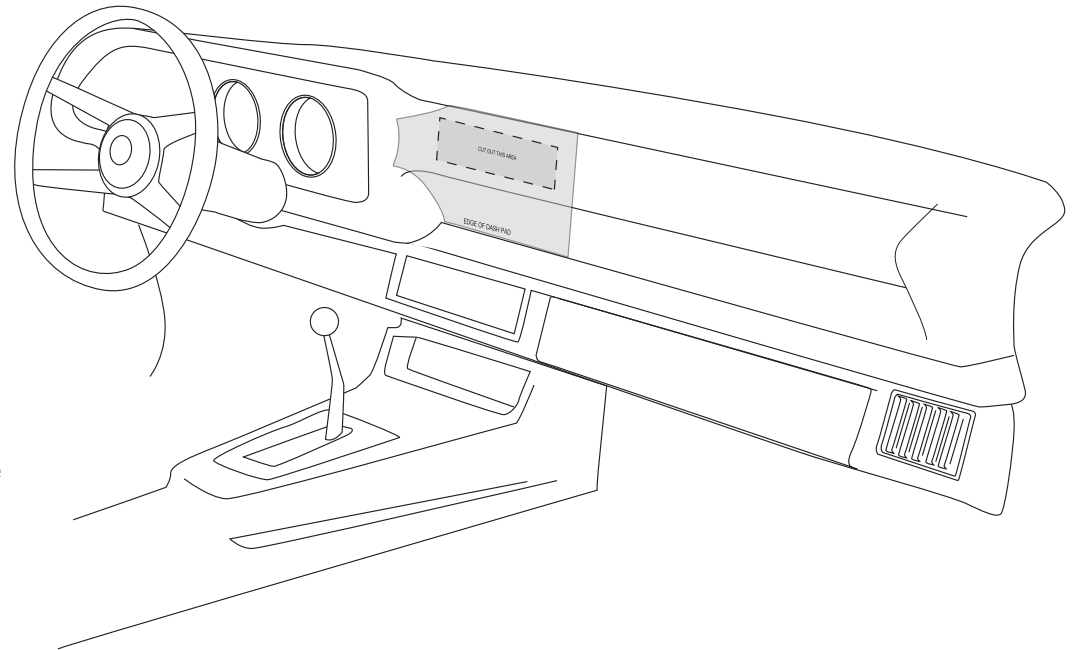

View from underside of dash

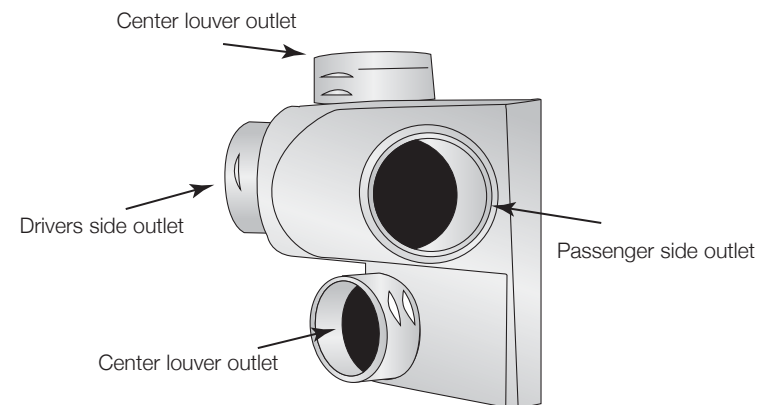

Attach louver adapters to the back side of OEM louvers, both sides. S-Clips will hold them in place.

Route supplied flex hoses as shown below. Take your time and route them so they don't become kinked or torn.

During installation of the hoses be aware of the eventual movement of the wiper arm components.



The smoother the route of the flex hoses the better the airflow.

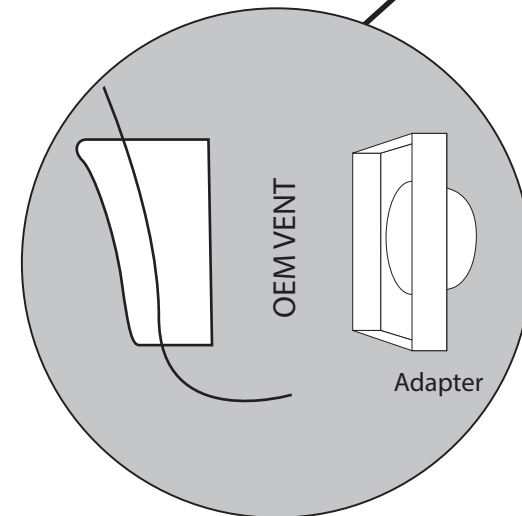
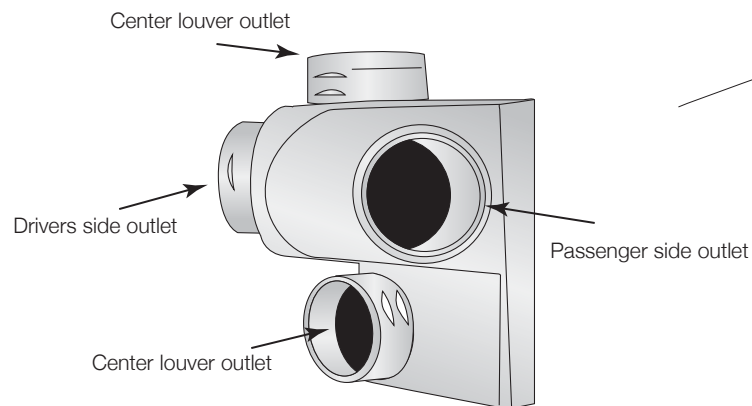
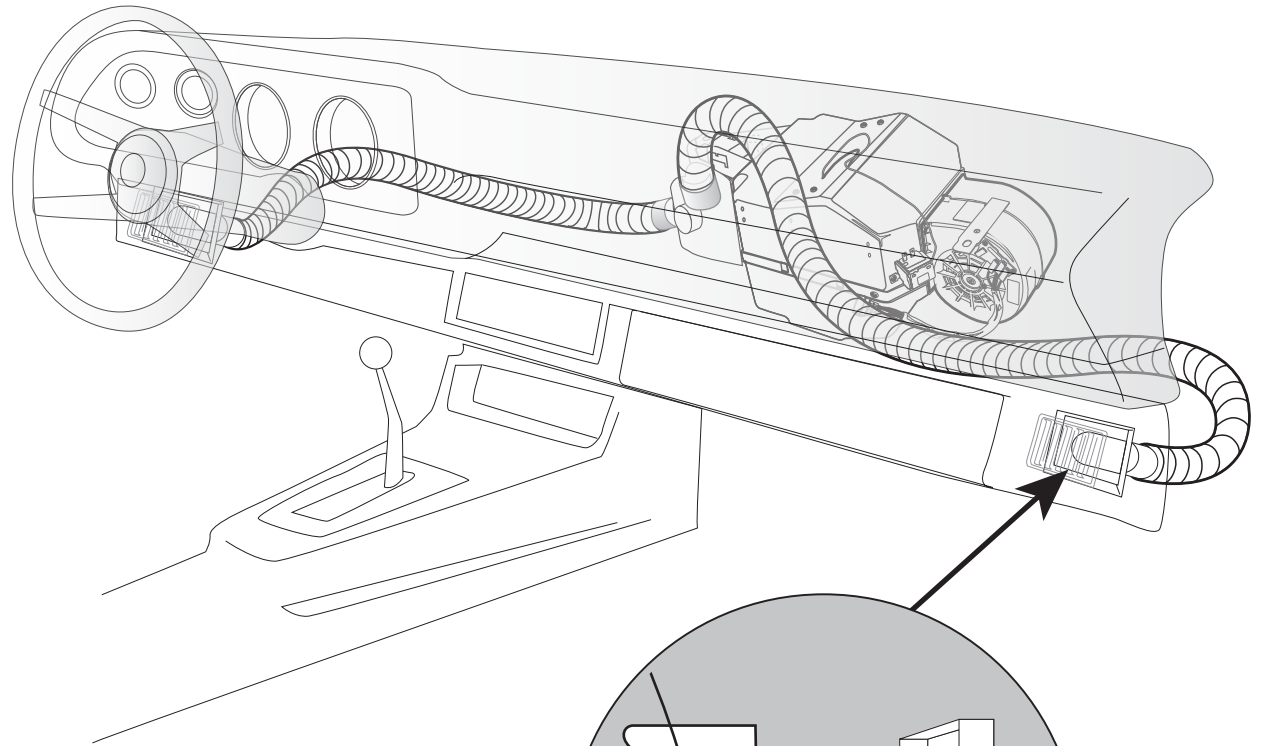





# THESE ARE THE PARTS YOU WILL NEED FOR THE ENGINE COMPARTMENT INSTALLATION

You'll find all of these parts within the main box

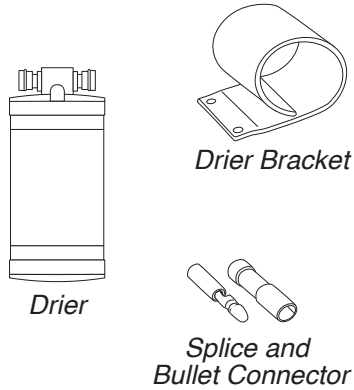

Drier Bracket

Drier

Splice and Bullet Connector

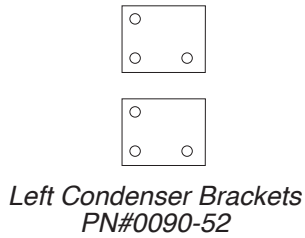

Left Condenser Brackets  
PN#0090-52

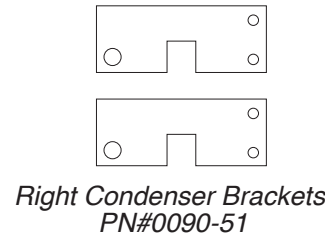

Right Condenser Brackets  
PN#0090-51

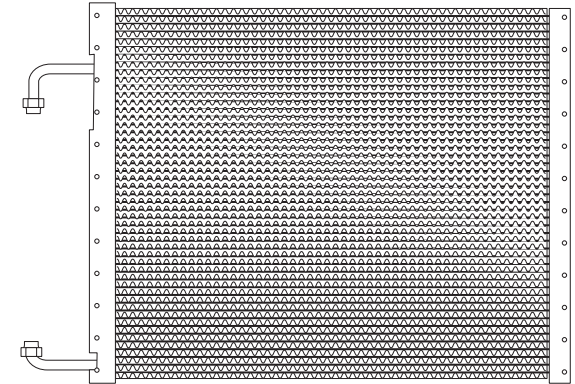

Condenser  
PN#11-1088



Nine #10 - 10 x 1/4" Hex Screws



Four 1/4" - #20 Flange Nuts



Four 1/4" - #20 x 5/8" Hex Head Bolts

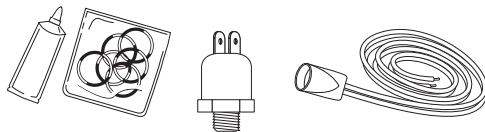

Pressure Switch and harness,  
Bag of O-rings and Mineral Oil Tube

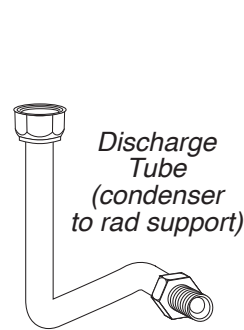

Discharge Tube  
(condenser to rad support)

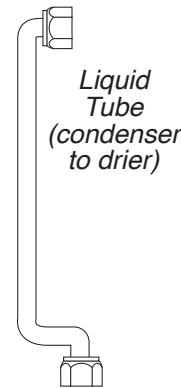

Liquid Tube  
(condenser to drier)

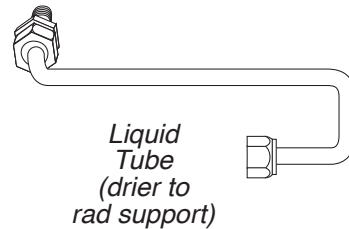

Liquid Tube  
(drier to rad support)

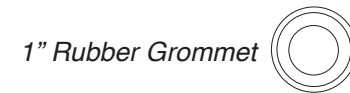

1" Rubber Grommet

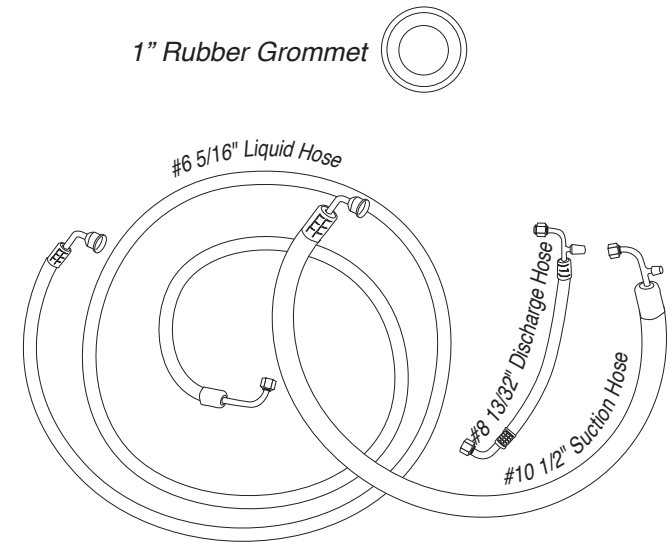

Three Refrigerant Hoses

Remove the hood latch assembly, radiator fan, and fan shroud. Retain original hardware.

Using the included template, attach it to the passenger side of the radiator bulkhead, and drill both needed holes as indicated. Put the included grommet into the 1" hole.

Place the condenser on a flat work surface with hose connections on the left (larger connection will be on top.) Attach the included brackets to the condenser, as shown to the right. Use the included hex screws, but do not tighten just yet.

Place the condenser in front of the radiator support and use original holes on the support to secure the condenser with the included 1/4" - #20 x 5/8" hex head bolts and flange nuts.

**INSTRUCTIONS FOR 1970-1973 CAMARO'S ONLY**

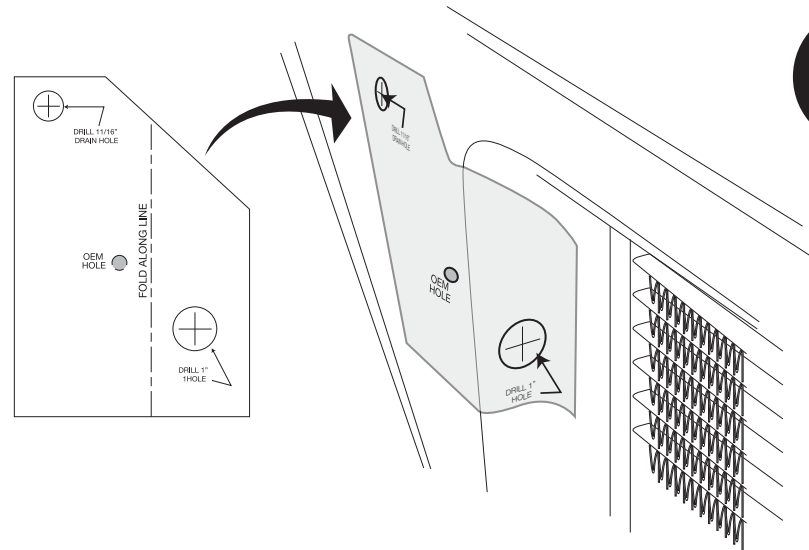

**2ND AND 3RD HOLES FROM TOP**

**3RD AND 4TH HOLES FROM BOTTOM**

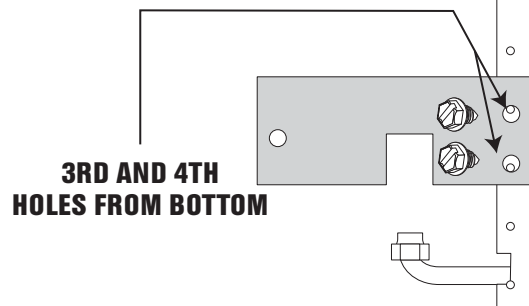
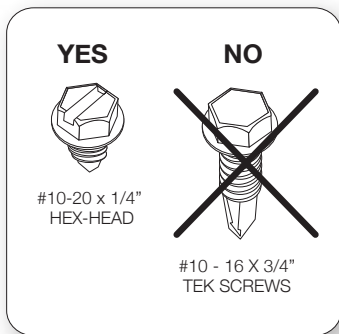

**DISCHARGE TUBE.** Insert discharge tube through grommet and attach to condenser using #8 o-ring and a few drops of mineral oil. Attach remaining condenser bracket to the 3rd hole from the top using (1) #10- 20 x 1/4" screw and secure it to the support with (1) 1/4" x 5/8" bolt and 1/4" flange nut in the original hole.

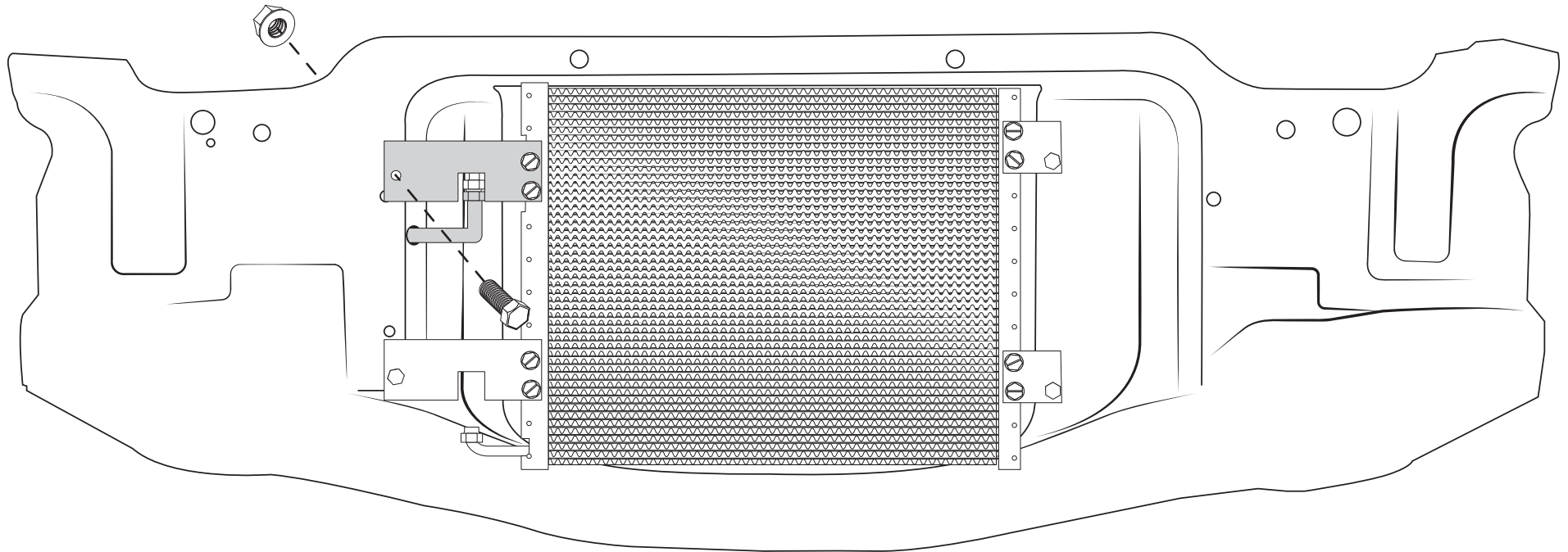

**DRIER PREPARATION.** The drier is conveniently mounted on the left hand side of the condenser. First insert the drier into the drier mounting bracket (it's basically a sleeve for the drier). Attach the drier liquid tube to the drier and also to the connection on the condenser (tighten connections at either end with #6 o-rings and a few drops of mineral oil). Attach the drier bracket to the condenser using (2) #10-20 x 1/4" screws through the bottom hole of the condenser bracket. Attach the remaining liquid tube to the drier using a #6 o-ring and mineral oil, then attach through 11/16" hole drilled in support.

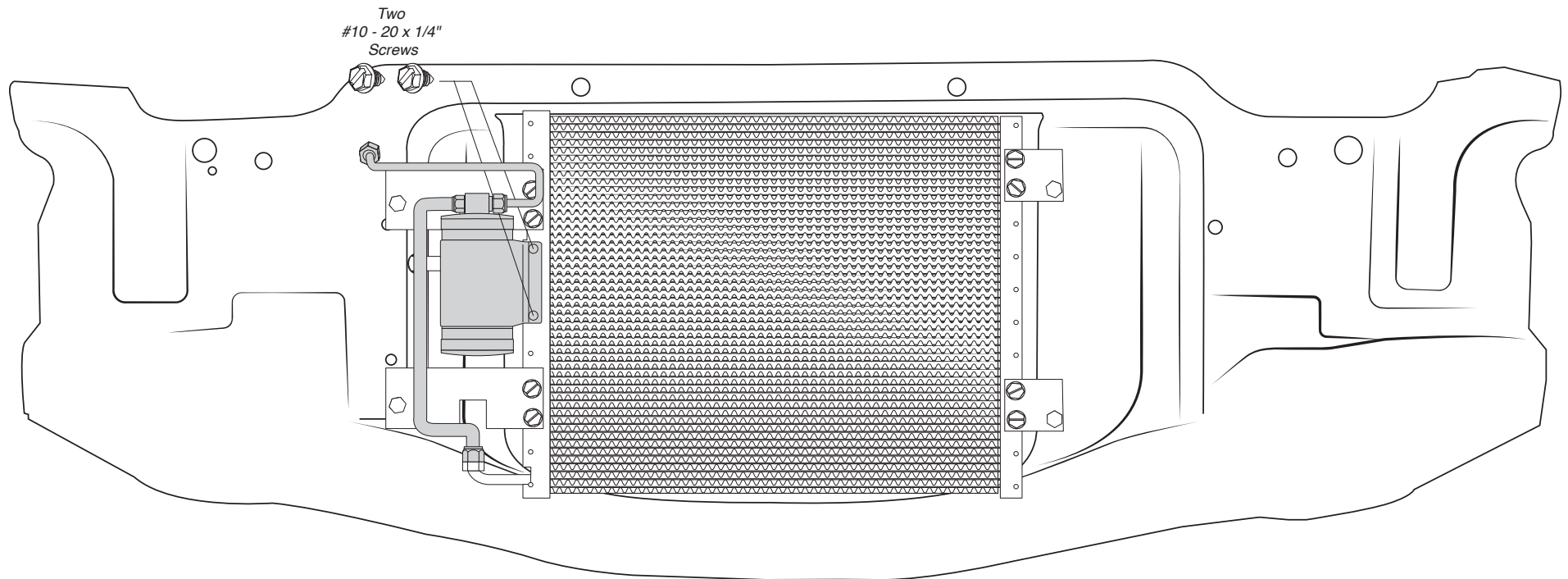

Reminder...  
Use two  
wrenches to  
tighten o-ring  
fittings

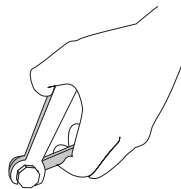

**PRESSURE SWITCH:** Screw the high-pressure switch into the port on the top of the drier. Go ahead and plug the pressure switch harness into the switch at this time (black electrical boot with two long white wires).

Reinstall hood latch, fan shroud and fan using original hardware.

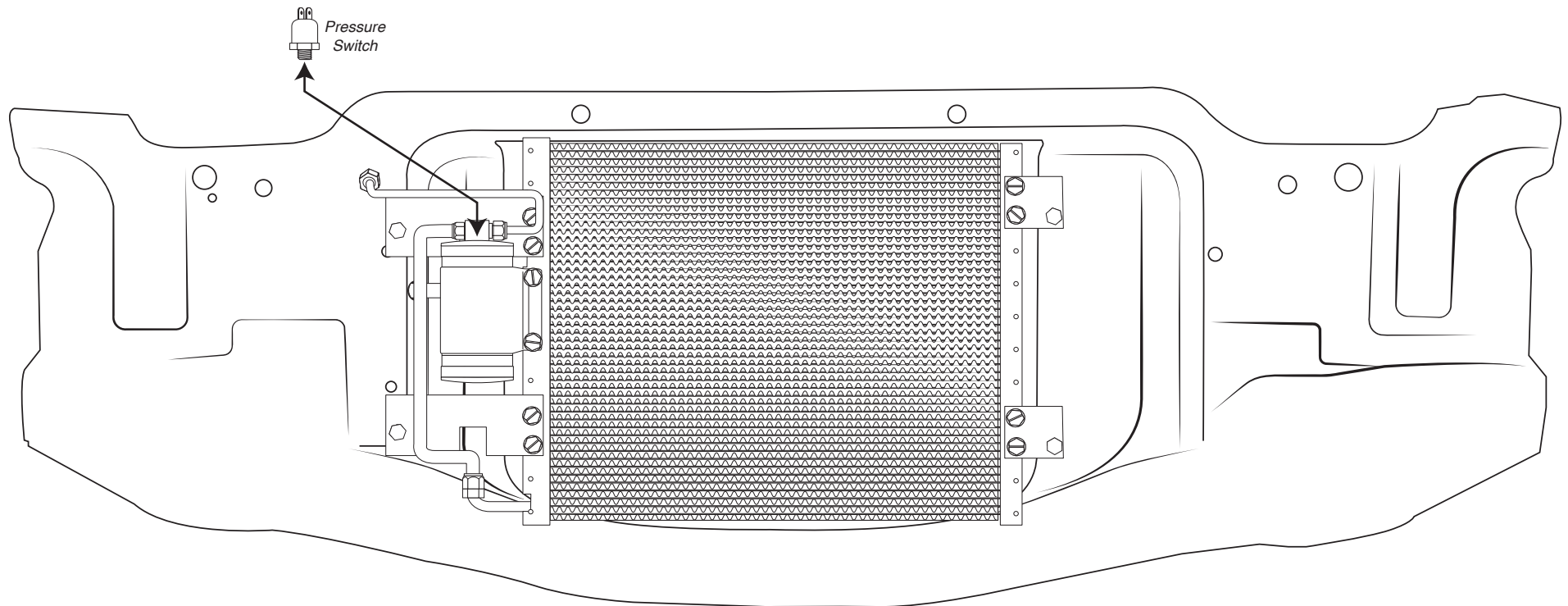





# THESE ARE THE PARTS YOU WILL NEED FOR THE ENGINE COMPARTMENT INSTALLATION

You'll find all of these parts within the main box

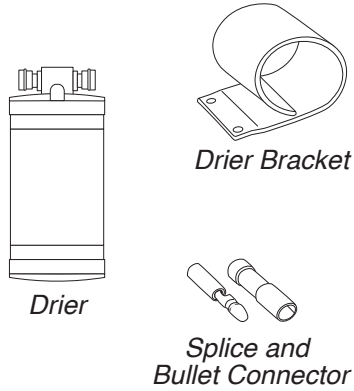

Drier Bracket

Drier

Splice and Bullet Connector

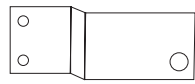

Right Condenser Bracket  
PN#0044-93

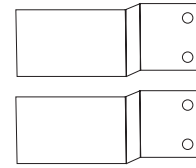

Left Condenser Brackets  
PN#0090-9

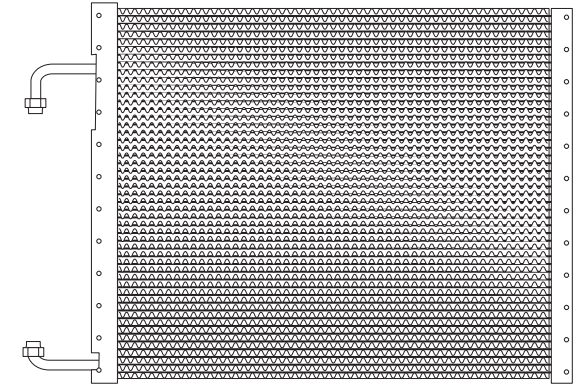

Condenser  
PN#11-1089



Eight #10 - 20 x 3/8" Screws



One #10 - 16 x 3/4" Tek Screws

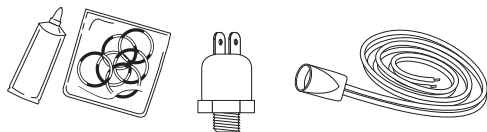

Pressure Switch and harness,  
Bag of O-rings and Mineral Oil Tube

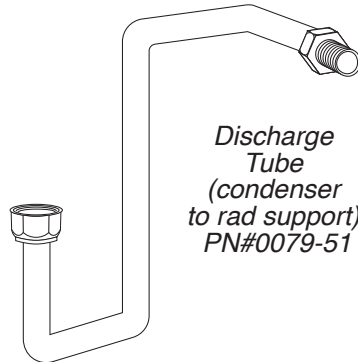

Discharge Tube  
(condenser to rad support)  
PN#0079-51

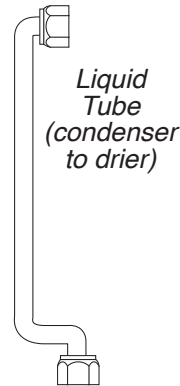

Liquid Tube  
(condenser to drier)

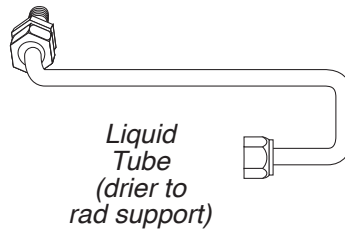

Liquid Tube  
(drier to rad support)



#8 Hose Clamp



1" Rubber Grommet

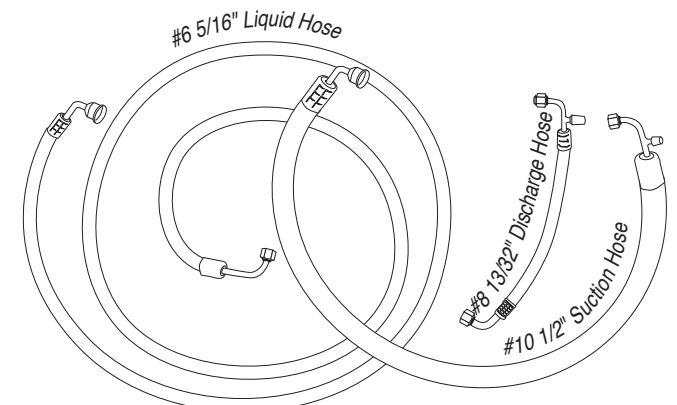

Three Refrigerant Hoses

Remove the hood latch assembly and horn assembly. Retain original hardware. Using the included template, fold along dotted line and align top edge with radiator cowl opening and tape. Drill holes as indicated on template. Put the included grommet into the 1" hole.

Lay the condenser down so that both hose connection are on the left side (larger connection will be on top).

Attach brackets to condenser as shown using (6)-10 x 1/4 tek screws.

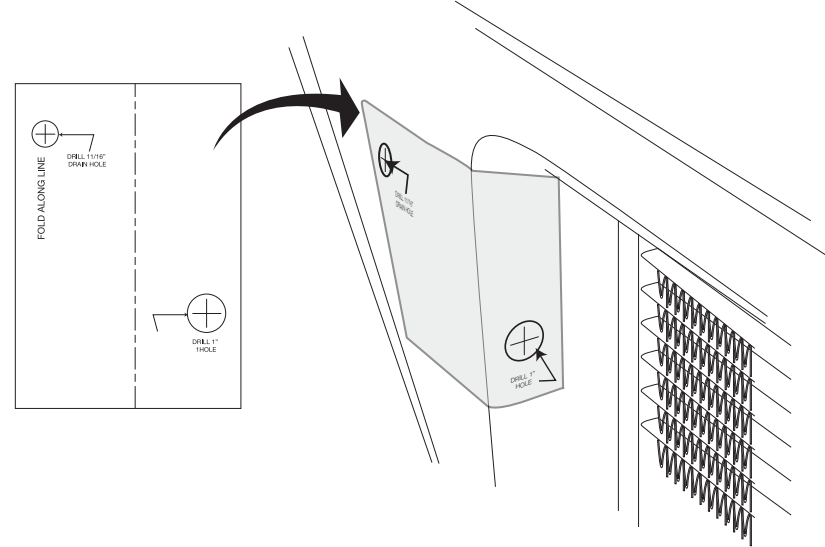

**INSTRUCTIONS FOR 1974-1978 CAMARO'S**

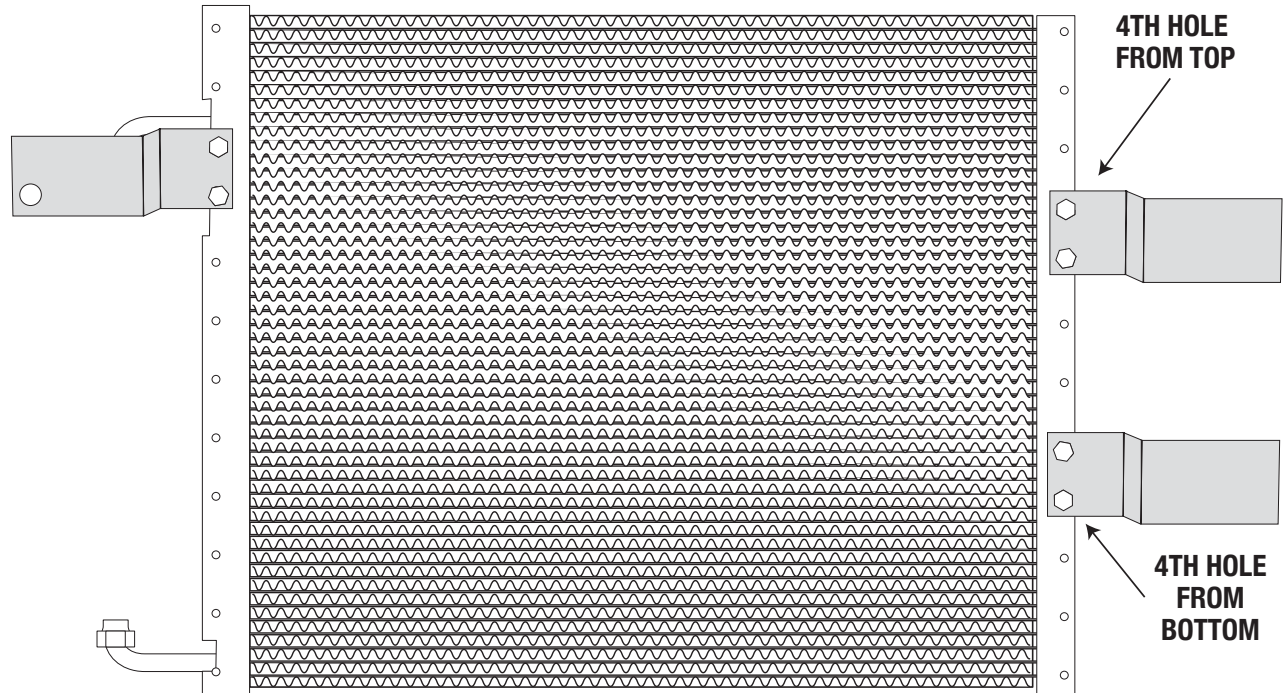
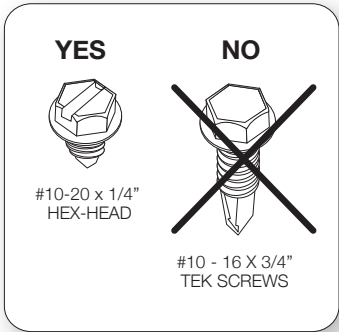

**DRIER PREPARATION.** The drier is conveniently mounted on the left hand side of the condenser. First insert the drier into the drier mounting bracket (it's basically a sleeve for the drier). Attach the drier liquid tube to the drier and also to the connection on the condenser (tighten connections at either end using supplied o-rings on both ends and a few drops of mineral oil to each o-ring). Attach the drier bracket to the condenser with the included #10-20 x 1/4" screws in the 4th hole from the bottom.

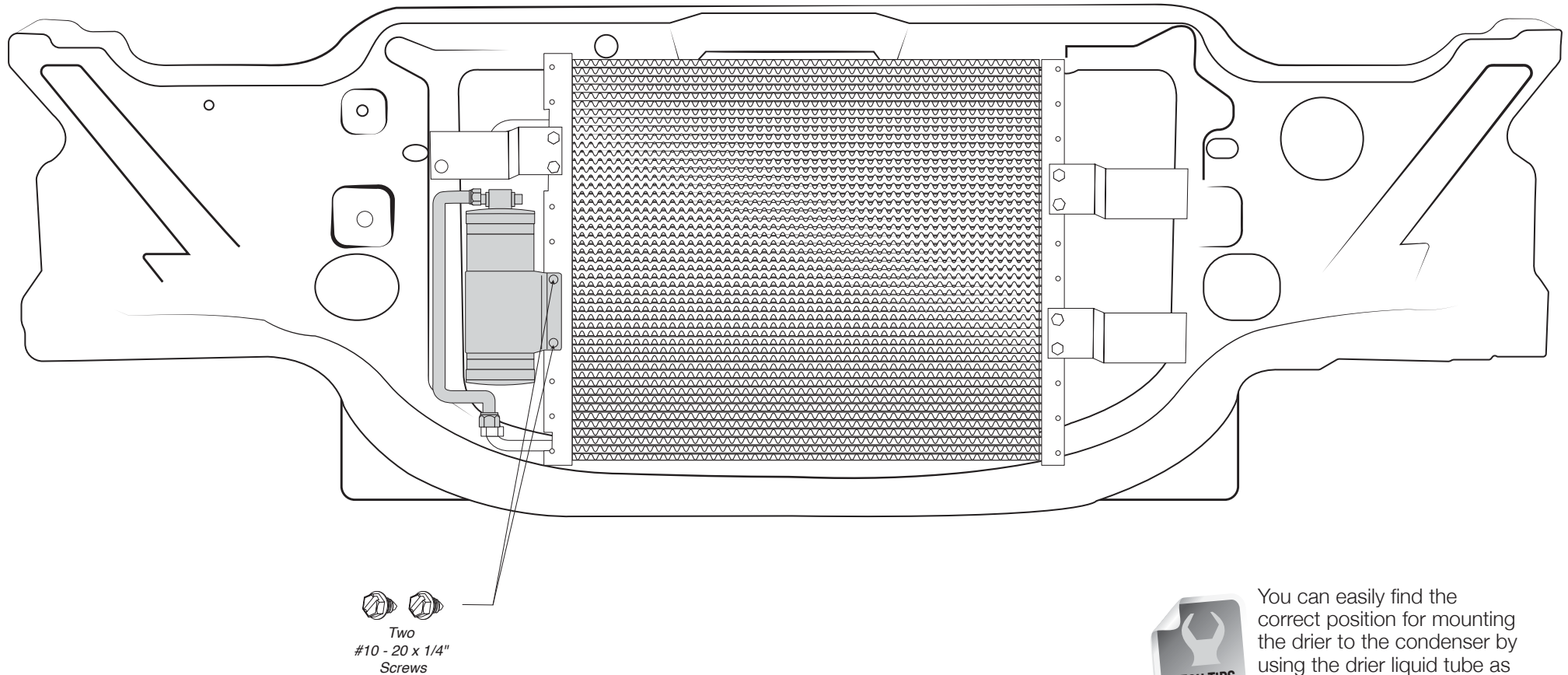

You can easily find the correct position for mounting the drier to the condenser by using the drier liquid tube as a gauge.



**PRESSURE SWITCH:** Screw the high-pressure switch into the port on the top of the drier. Go ahead and plug the pressure switch harness into the switch at this time (black electrical boot with two long white wires).

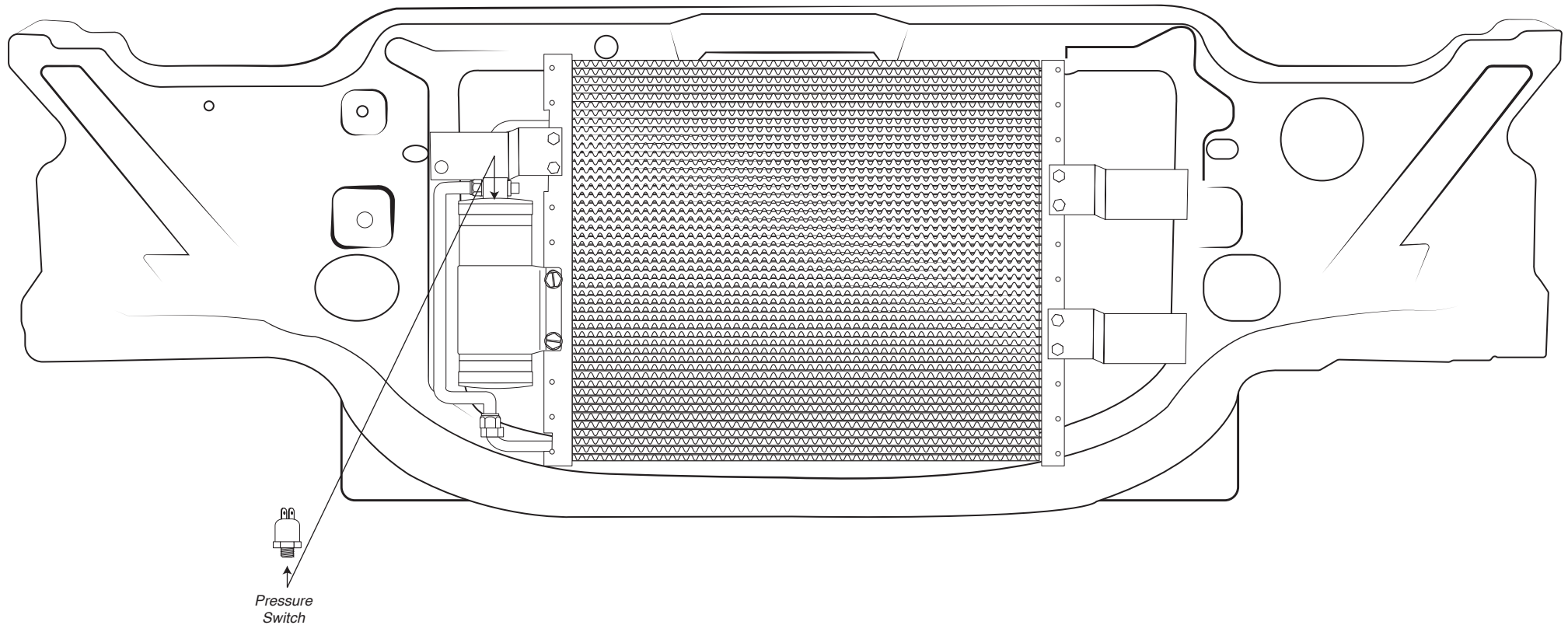

Remove and retain top 2 OEM screws on the radiator cowl brackets. Loosen bottom 2 OEM screws on bracket side condenser down in front of radiator and slide condenser brackets between cowl and cowl brackets. Reinstall original hardware for cowl brackets.

Locate the Liquid tube and, (1) #6 o-ring. Attach liquid tube to drier using o-ring and a few drops of mineral oil. Attach tube to cowl through 11/16" drilled hole.

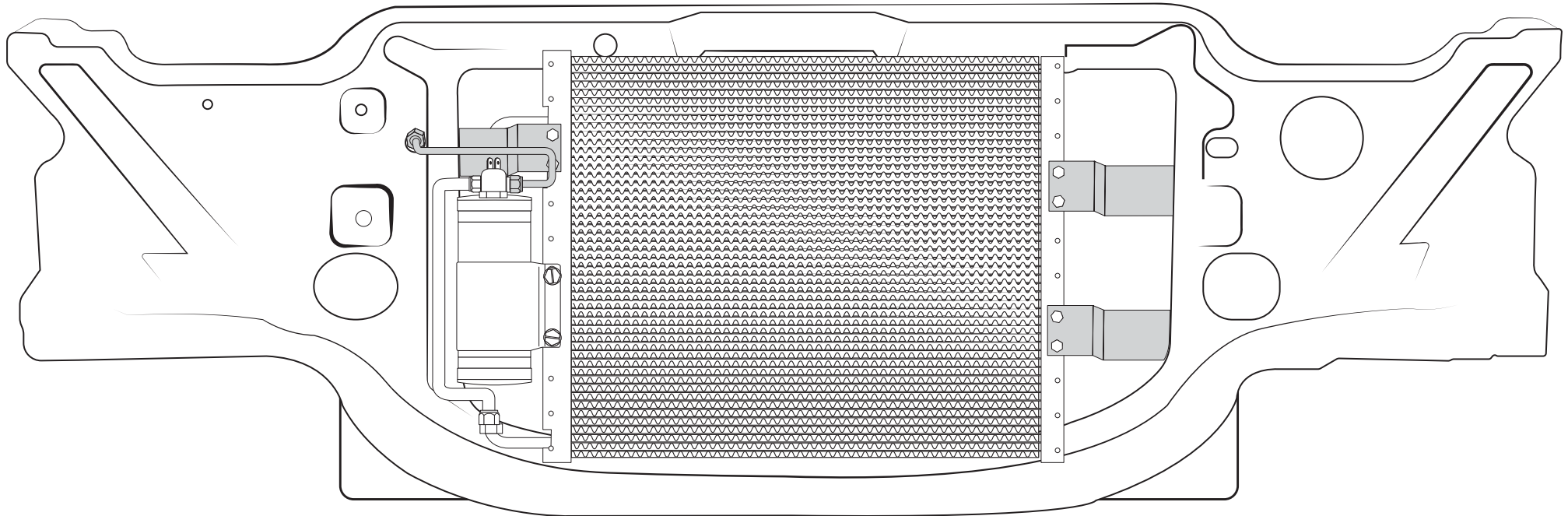

Locate discharge tube and (1) #8 o-ring. Route tube through previously installed grommet. Attach tube to condenser using o-ring and a few drops of mineral oil. Attach tube to cowl with hose clamp and (1) #10 x 3/4" Tek screw.

Reinstall hood latch assembly and horn assembly using original hardware.

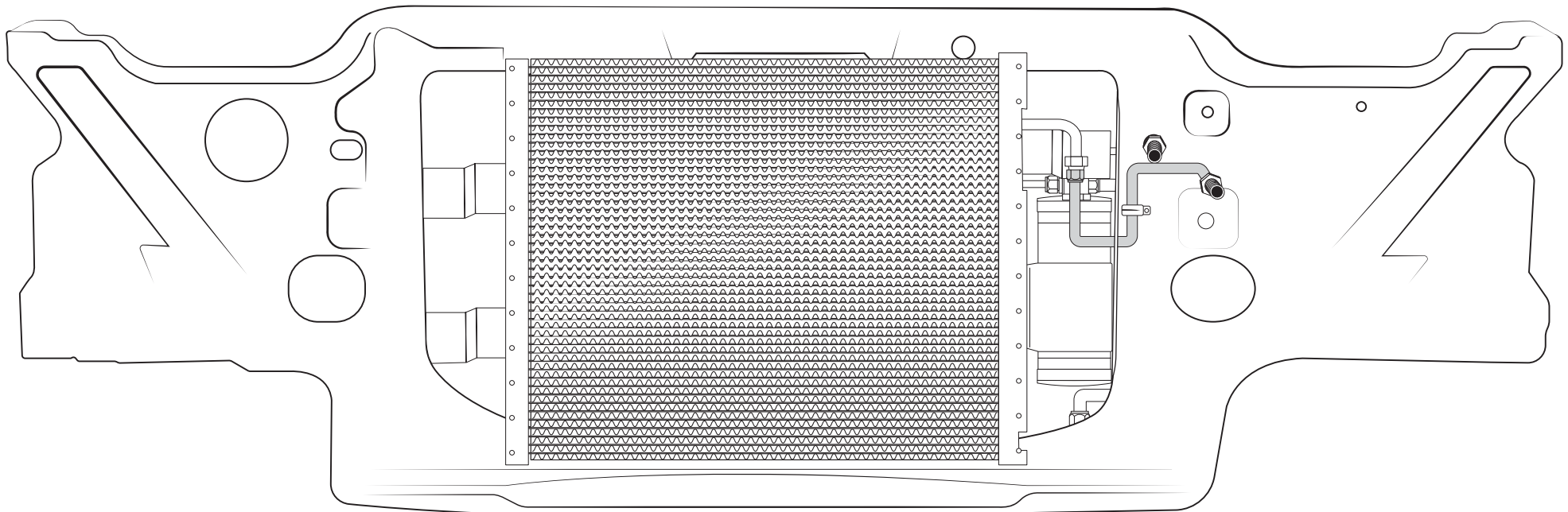

**Install the compressor kit.** Included was a premium compressor kit with all the parts you'll need to install the compressor. This kit includes instructions specifically written for your engine. Once you've installed the complete compressor kit, continue on to connecting the hoses.

### CONNECTING THE HOSES:

**Based on PASSENGER or DRIVERS SIDE compressor mounting see illustrations for routing.**

The #10 (**LARGEST**) refrigerant hose. Attach end with service fitting to the compressor using (1) #10 o-ring and a few drops of mineral oil. Attach other end to #10 fitting at the firewall. Attach using one #10 o-ring and a few drops of mineral oil. Tighten securely.

The #6 (**SMALLEST**) refrigerant hose. Route behind fender and to the connection on firewall. Attach using two #6 o-ring and a few drops of mineral oil.

The #8 (**MEDIUM**) refrigerant Hose. Route behind fender and to the connection on compressor. Attach using two #8 o-ring and a few drops of mineral oil.

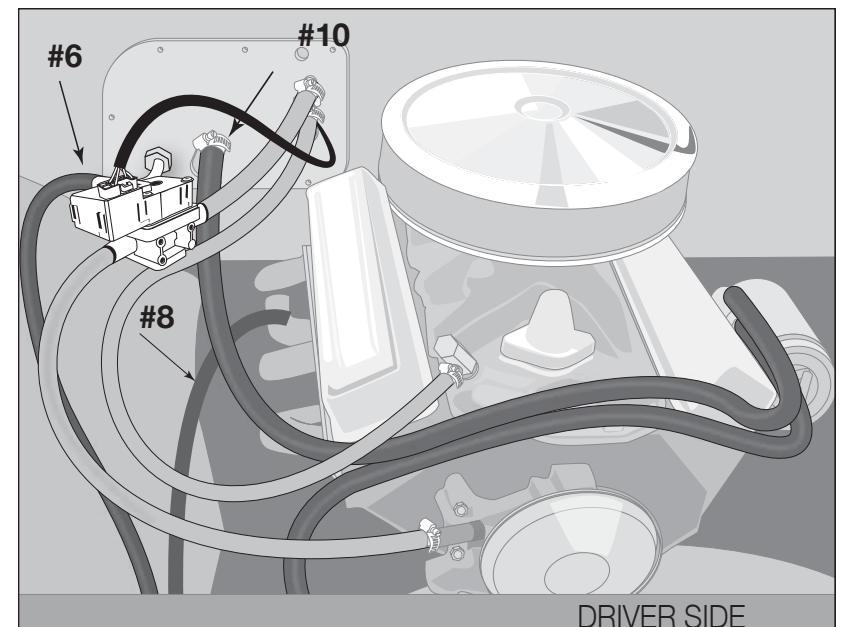
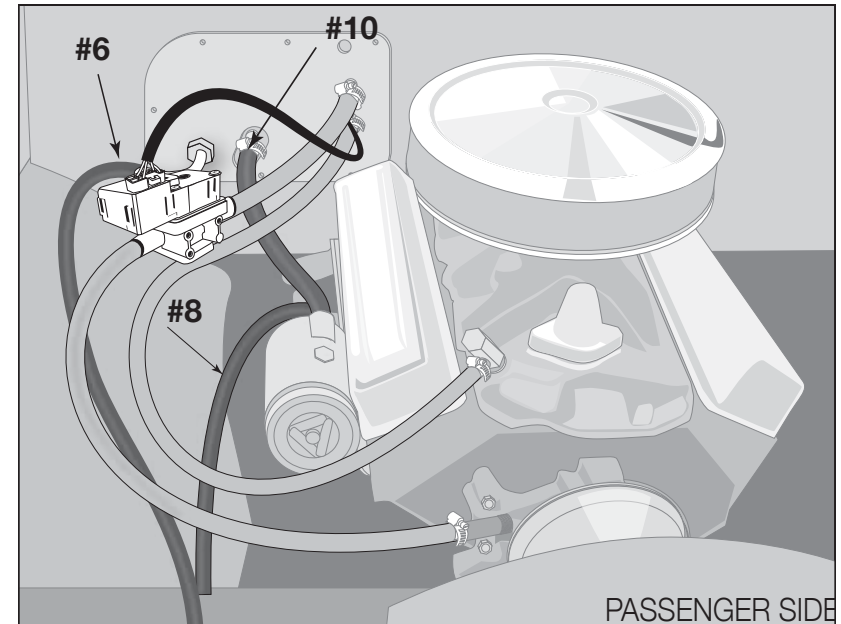

### TWO WRENCH METHOD

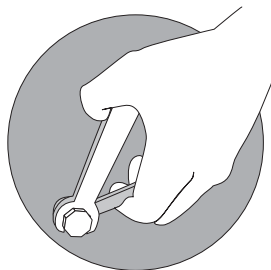

**Reminder...**  
Use two  
wrenches to  
tighten o-ring  
fittings

# New A/C System Preparation... A MUST READ!

Please read through these procedures before completing this new A/C system charging operation.

A licensed A/C technician should be utilized for these procedures to insure that your new system will perform at it's peak, and that your compressor will not be damaged.



- 1) Your radiator/cooling system is an integral part of your new system. Please insure that you have a 50/50 mix of distilled water and antifreeze. The heater coil **MUST** be purged (cycle heater control valve) to make sure no water, without antifreeze, is in the heater coil before you charge the A/C system.
- 2) Evacuate the system for 45 minutes (minimum).
- 3) **Your new compressor MUST be hand-turned 15-20 revolutions before and after charging with liquid. Failure to do this may cause the reed valves to become damaged** (this damage is NOT covered by your warranty).
- 4) Your new system requires 134a refrigerant. It will require 1.5 lbs (or 24 oz).
- 5) Your new compressor comes charged with oil - NO additional oil is needed.
- 6) Insure that the new belt is tight.
- 7) **DO NOT CHARGE SYSTEM WITH LIQUID REFRIGERANT!**

## RECOMMENDED TEST CONDITIONS: (After system has been fully charged and tested for basic operation)

- Determine the temperature outside of the car
- Connect gauges or service equipment to high/low charging ports
- Place blower fan switch on medium
- Close all doors and windows on vehicle
- Place shop fan directly in front of condenser
- Run engine idle up to approx. 1500 rpm

## ACCEPTABLE OPERATING PRESSURE RANGES:

1. HIGH-SIDE PRESSURES (150-275 PSI)
2. LOW-SIDE PRESSURES (10-25 PSI in a steady state)

Readings above are based on an ambient temperature of 90° with an adequate airflow on condenser

CENTERLINE OF THE OIL FILL BOLT

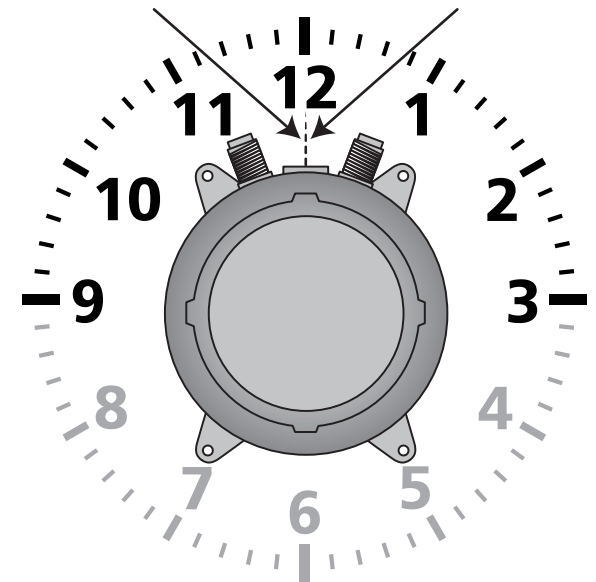

**CAUTION!** When mounting your compressor and/or adjusting the belt use caution. Mount by using the centerline of the oil fill plug as your guide. The compressor can **ONLY** be mounted in between the 9 to 3 positions. **DO NOT** mount in between the 4 to 8 positions.

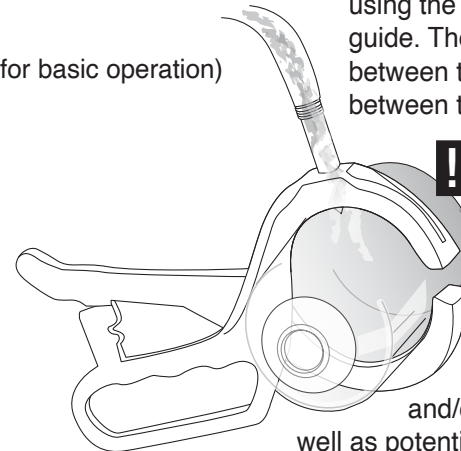

**Do NOT tilt, shake or turn refrigerant can upside-down OR use a charging station to install refrigerant while the engine is running.**

Doing so will direct liquid refrigerant into the compressor piston chamber, causing damage to reed valves and/or pistons and/or other components, as well as potentially seizing the compressor. Allow a minimum of 30 minutes for liquid to "boil off." You must hand turn the compressor hub (not the pulley) a minimum of 15 complete revolutions prior to starting the engine with the clutch engaged.



---

## TROUBLESHOOTING GUIDE

### TEST CONDITIONS USED TO DETERMINE SYSTEM OPERATION

*(THESE TEST CONDITIONS WILL SIMULATE THE AFFECT OF DRIVING THE VEHICLE AND GIVE THE TECHNICIAN THE THREE CRITICAL READINGS THAT THEY WILL NEED TO DIAGNOSE ANY POTENTIAL PROBLEMS).*

- B. CONNECT GAUGES OR SERVICE EQUIPMENT TO HIGH/LOW CHARGING PORTS.
- C. PLACE BLOWER FAN SWITCH ON MEDIUM.
- D. CLOSE ALL DOORS AND WINDOWS ON VEHICLE.
- E. PLACE SHOP FAN IN FRONT OF CONDENSER.
- F. RUN ENGINE IDLE UP TO 1500 RPM.

### ACCEPTABLE OPERATING PRESSURE RANGES (R134A TYPE)

- 1. HIGH-SIDE PRESSURES ( 150-275 PSI ) *\*Note- general rule of thumb is two times the ambient (daytime) temperature, plus 15-20%.*
- 2. LOW-SIDE PRESSURES ( 10-25 PSI in a steady state).

CHARGE AS FOLLOWS: R134A = 24 OZ.  
NO ADDITIONAL OIL IS NECESSARY IN OUR NEW COMPRESSORS.

### TYPICAL PROBLEMS ENCOUNTERED IN CHARGING SYSTEMS

**NOISY COMPRESSOR.** A noisy compressor is generally caused by charging a compressor with liquid or overcharging

- A. If the system is overcharged both gauges will read abnormally high readings. This is causing a feedback pressure on the compressor causing it to rattle or shake from the increased cylinder head pressures. System must be evacuated and re-charged to exact weight specifications.
- B. Heater control valve installation - Installing the heater control valve in the incorrect hose. Usually when this occurs the system will cool at idle then start to warm up when raising the RPM's of the motor. THE HEATER CONTROL IS A DIRECTIONAL VALVE; MAKE SURE THE WATER FLOW IS WITH THE DIRECTION OF THE ARROW. As the engine heats up that water transfers the heat to the coil, thus overpowering the a/c coil. A leaking or

faulty valve will have a more pronounced affect on the unit's cooling ability. Installing the valve improperly (such as having the flow reversed) will also allow water to flow through, thus inhibiting cooling. Check for heat transfer by disconnecting hoses from the system completely. By running down the road with the hoses looped backed through the motor, you eliminate the possibility of heat transfer to the unit.

- C. Evaporator freezing - Freezing can occur both externally and internally on an evaporator core. External freeze up occurs when the coil cannot effectively displace the condensation on the outside fins and the water forms ice (the evaporator core resembles a block of solid ice), it restricts the flow of air that can pass through it, which gives the illusion of the air not functioning. The common cause of external freezing is the setting of the thermostat and the presence of high humidity in the passenger compartment. All door and window seals should be checked in the event of constant freeze-up. A thermostat is provided with all units to control the cycling of the compressor.
- D. Internal freeze up occurs when there is too much moisture inside the system. The symptoms of internal freeze up often surface after extended highway driving. The volume of air stays constant, but the temperature of the air gradually rises. When this freezing occurs the low side pressure will drop, eventually going into a vacuum. At this point, the system should be checked by a professional who will evacuate the system and the drier will have to be changed.
- E. Inadequate airflow to condenser - The condenser works best in front of the radiator with a large supply of fresh air. Abnormally high pressures will result from improper airflow. Check the airflow requirements by placing a large capacity fan in front of the condenser and running cool water over the surface. If the pressures drop significantly, this will indicate the need for better airflow.
- F. Incorrect or inadequate condenser capacity - Incorrect condenser capacity will cause abnormally high head pressures. A quick test that can be performed is to run cool water over the condenser while the system is operating, if the pressures decrease significantly, it is likely a airflow or capacity problem.
- G. Expansion valve failure - An expansion valve failure is generally caused by dirt or debris entering the system during assembly. If an expansion valve fails it will be indicated by abnormal gauge readings. A valve that is blocked will be indicated by high side that is unusually high, while the low side will be unusually low or may even go into a vacuum. A valve that is stuck open will be indicated by both the high and low pressures rising to unusually high readings, seeming to move toward equal readings on the gauges.
- H. Restrictions in system - A restriction in the cooling system will cause abnormal readings on the gauges. A high-side restriction ( between the compressor and the drier inlet ) will be indicated by the discharge gauges reading excessively high. These simple tests can be performed by a local shop and can help determine the extent of the systems problem.

## Trouble Shooting Your Classic Auto Air A/C System

**PROBLEM:** system is not cooling properly

**ISSUE:** cold at idle, warmer when raising engine RPM's

### Make sure the Water Valve is positioned correctly

The water valve is a directional valve and should be installed with the arrow pointing towards the water pump, it should be connected to the heater hose that runs from the heater core to the water pump. If the water valve is connected to the incorrect hose it allows water to circulate through the system via the heater core over powering the cooling effect of the A/C coil, (normally the air conditioning is functioning properly).

Step 1: Check placement of the water valve, correct if needed. (In some cases changing the location of the water valve may not fix the above problem.) Continue to next step.

Step 2 If changing the location of the water valve does not rectify the issue, then possibly the water valve is permanently damaged and may need to be replaced. To check the integrity of the water valve completely remove the water hoses for the heater core and "loop" together. (This will remove the heater system completely from the possibilities) If the system now cools, replace the water valve

### Verify Adequate Air Flow to Condenser

For an air conditioning system to function properly there has to be adequate airflow across the condenser. The function of the condenser is to dissipate heat, without proper airflow your system will not cool correctly in the cabin of your vehicle.

Step 1: connect gauges to a/c hoses. The pressures should be: with the ambient temp is 90, low side pressures should be between 10-25 psi, high side pressures should be between 150-275 psi

Step 2: IF the low side pressures are normal and the high side pressures are high then there might be an airflow issue, continue to next step.

To test air flow to Condenser do the following three tests:

1. Place a piece of paper on the condenser with the car in idle and see if paper is held in place.
2. With car in idle, attach gages, and place a large capacity fan in front of

the condenser. What happens to the pressures?

3. With car still in idle and gages attached, pour water down the front of the condenser. What happens to the pressures?

If the paper is held in place you are at least getting some air flow. If the high side decreases during test 2 & 3 then your condenser is not getting enough air which is causing your system to not cool properly. To correct this issue you will need a more powerful mechanical fan.

Step 3: Confirm correct Refrigerant charge in System

All of our systems should be charged with 24 oz or 1.5 lbs of R134A Refrigerant only. If overcharged you will need to evacuate the system and recharge with the correct amount.\*

What measurements mean:

Low Temp and High Pressure seem to be equal...

You have a malfunctioning expansion valve that is stuck open.

High Side is extremely high and Low Side is extremely low (possibly into vacuum)...

There is a blockage in the system. Remove hoses and blow compressed air through in both directions. If pressures don't change its possible that your expansion valve is stuck closed and would have to be replaced.

### \*Compressor Concerns:

This is often misdiagnosed as a problem for the system not cooling properly. If you have a noisy compressor it is due to improper charging of refrigerant. An overcharged (more than 24 oz or 1.5 lbs R134A) compressor can cause rattling. If charged with pure liquid there is a high probability you have bent reed valves that are causing tapping sound.

**SCAN** QR code  
with your mobile camera

Get the technical support you want the moment you need it, with no wait times. Simply **SCAN** the **QR code** and be directly taken to our support section to troubleshoot all things A/C.

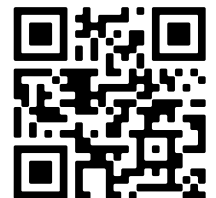



## Classic Auto Air Hardware Reference Guide

This is our basic line-up of hardware. No single kit will not contain all of these, but you can use this guide to match-up hardware for shape and size (all of these are actual size.)

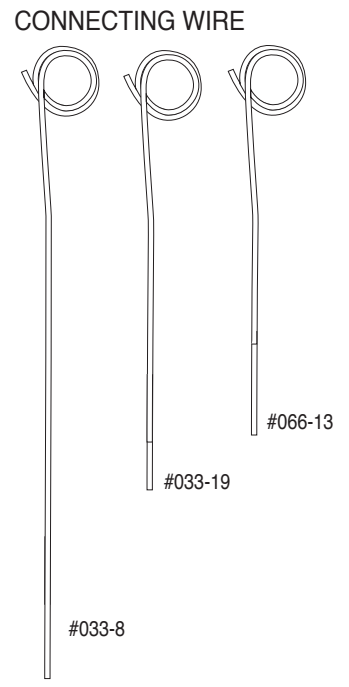
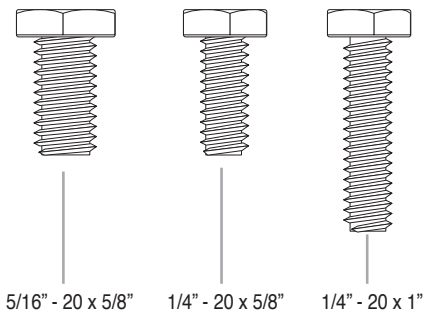
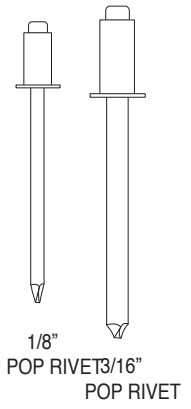
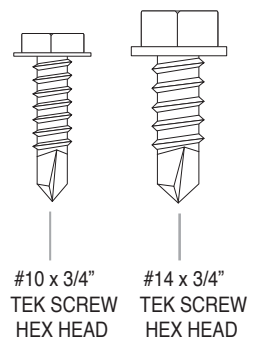
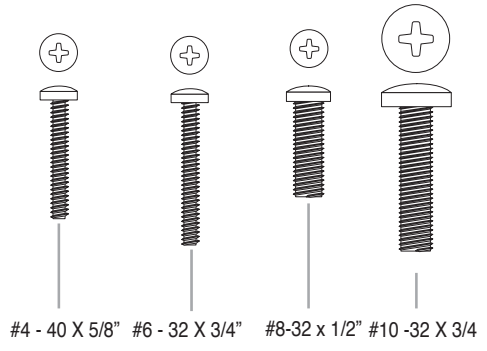
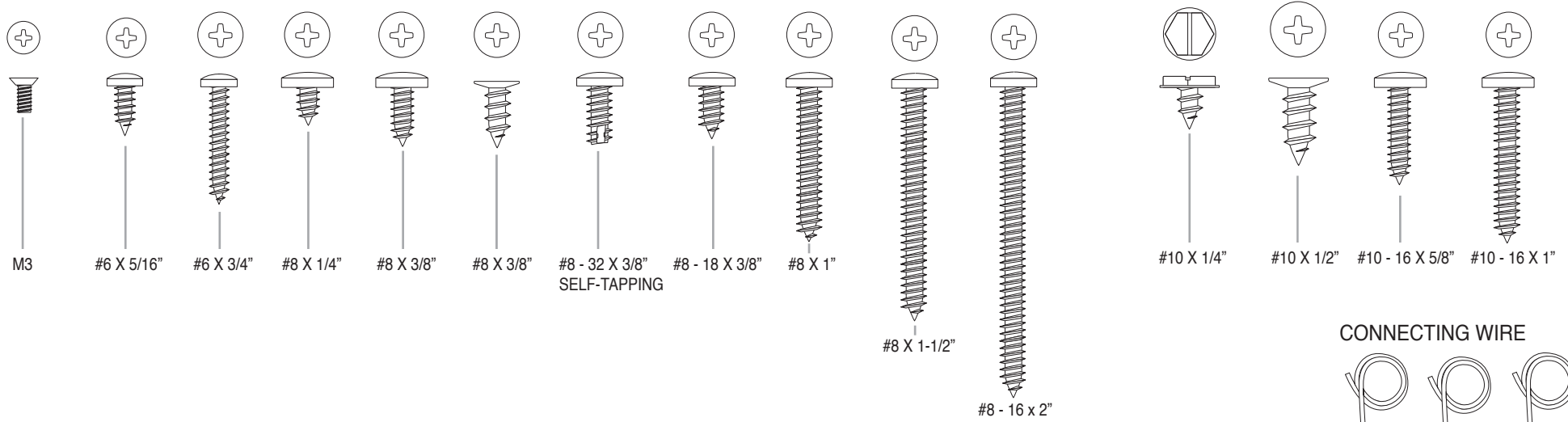

### LOCK NUTS



### NUTS AND WASHERS





Classic Auto Air Hardware Reference Guide

O-RINGS

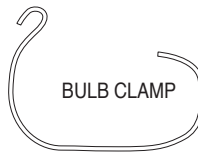
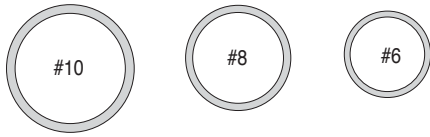

BULB CLAMP

CLIPS

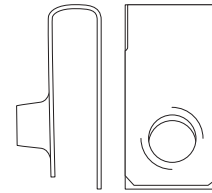

J-CLIP

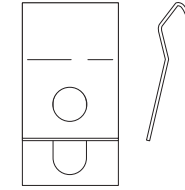

CABLE CLIP

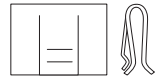

DUCT HOSE CLIP

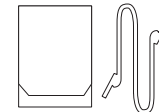

S-CLIP

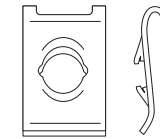

U-CLIP 10 X 32

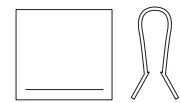

U-TYPE FASTENER

GROMMETS

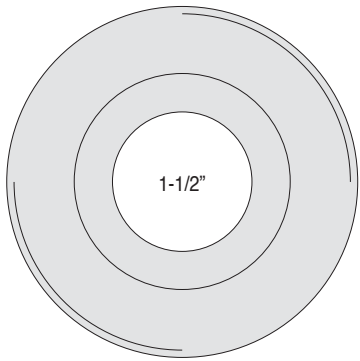

1-1/2"

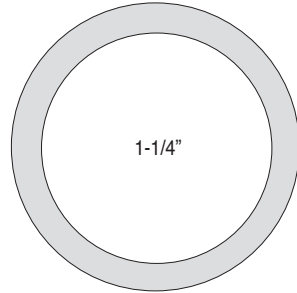

1-1/4"

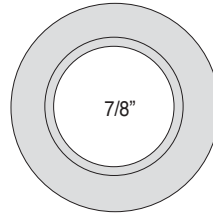

7/8"

HOLE PLUGS

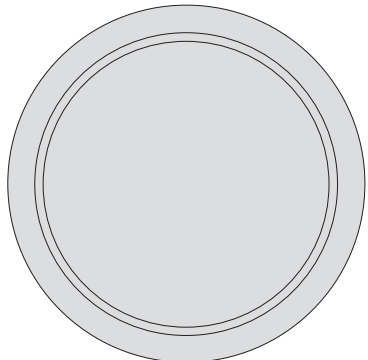

1-1/2"

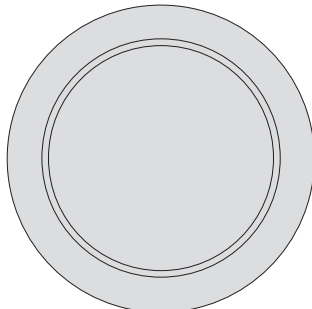

1-1/4"

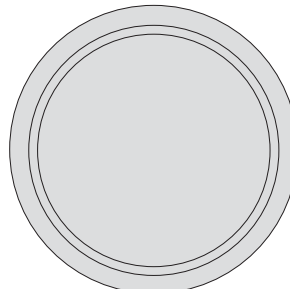

1-1/8"

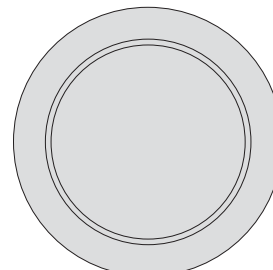

1"

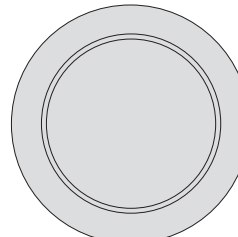

7/8"

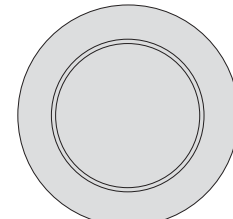

3/4"

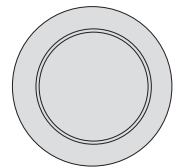

1/2"

HOSE CLAMPS

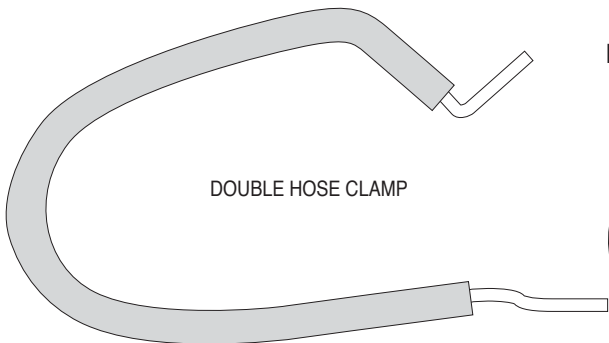

DOUBLE HOSE CLAMP

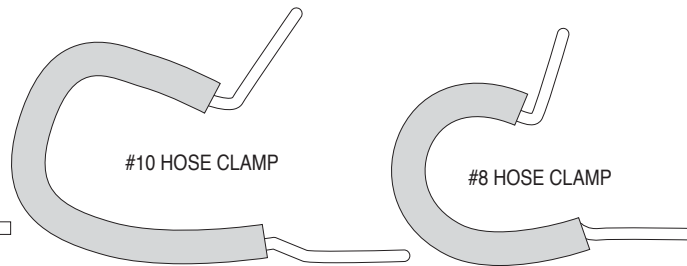

#10 HOSE CLAMP

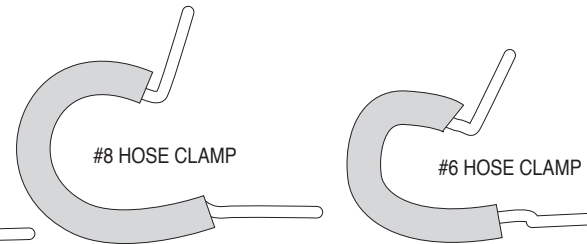

#8 HOSE CLAMP

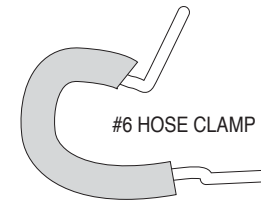

#6 HOSE CLAMP



WORM GEAR CLAMP



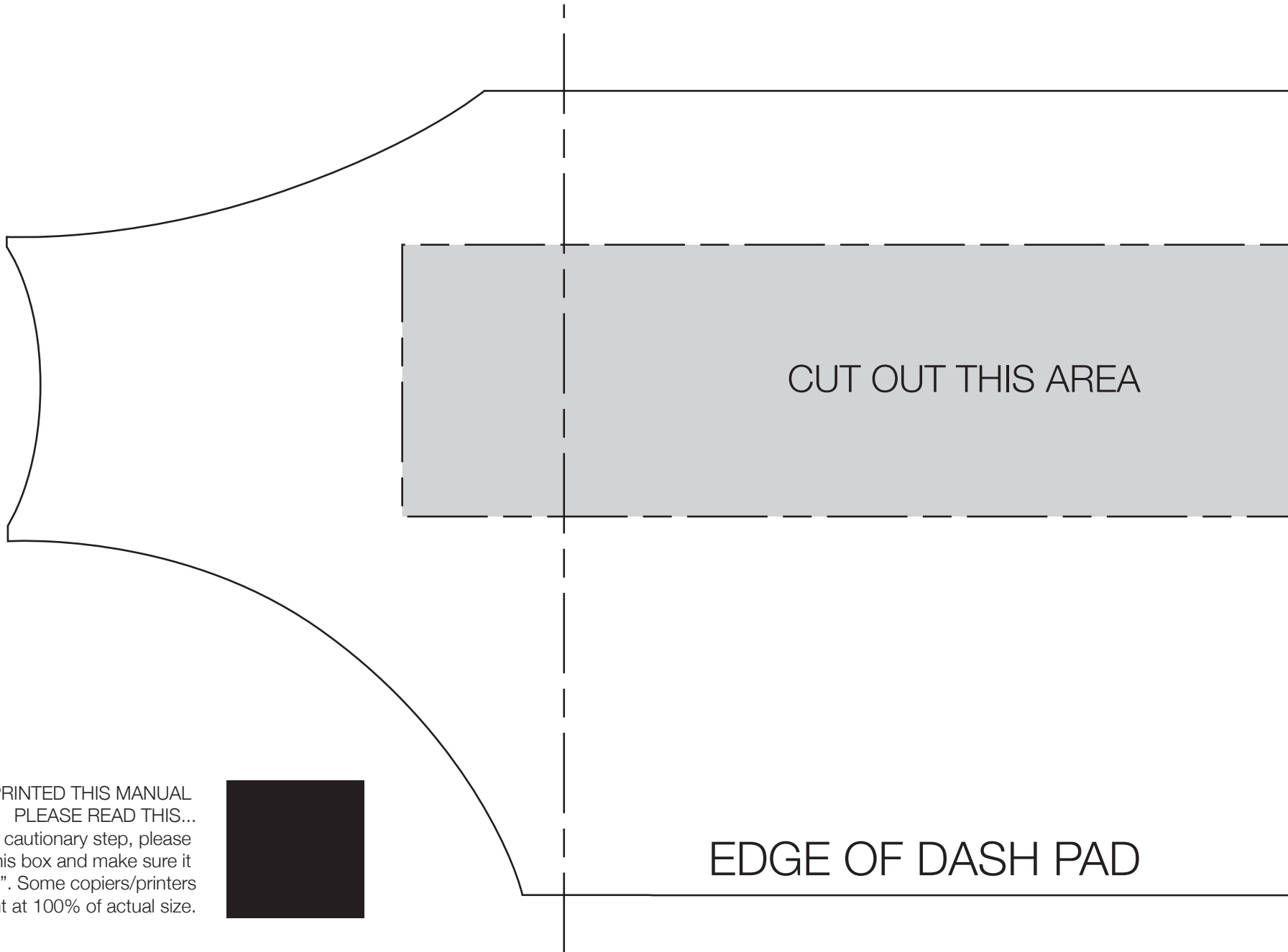

IF YOU PRINTED THIS MANUAL  
PLEASE READ THIS...  
Just as a cautionary step, please  
measure this box and make sure it  
is 1" x 1". Some copiers/printers  
may not print at 100% of actual size.







CUT OUT THIS AREA

IF YOU PRINTED THIS MANUAL  
PLEASE READ THIS...  
Just as a cautionary step, please  
measure this box and make sure it  
is 1" x 1". Some copiers/printers  
may not print at 100% of actual size.



EDGE OF DASH PAD



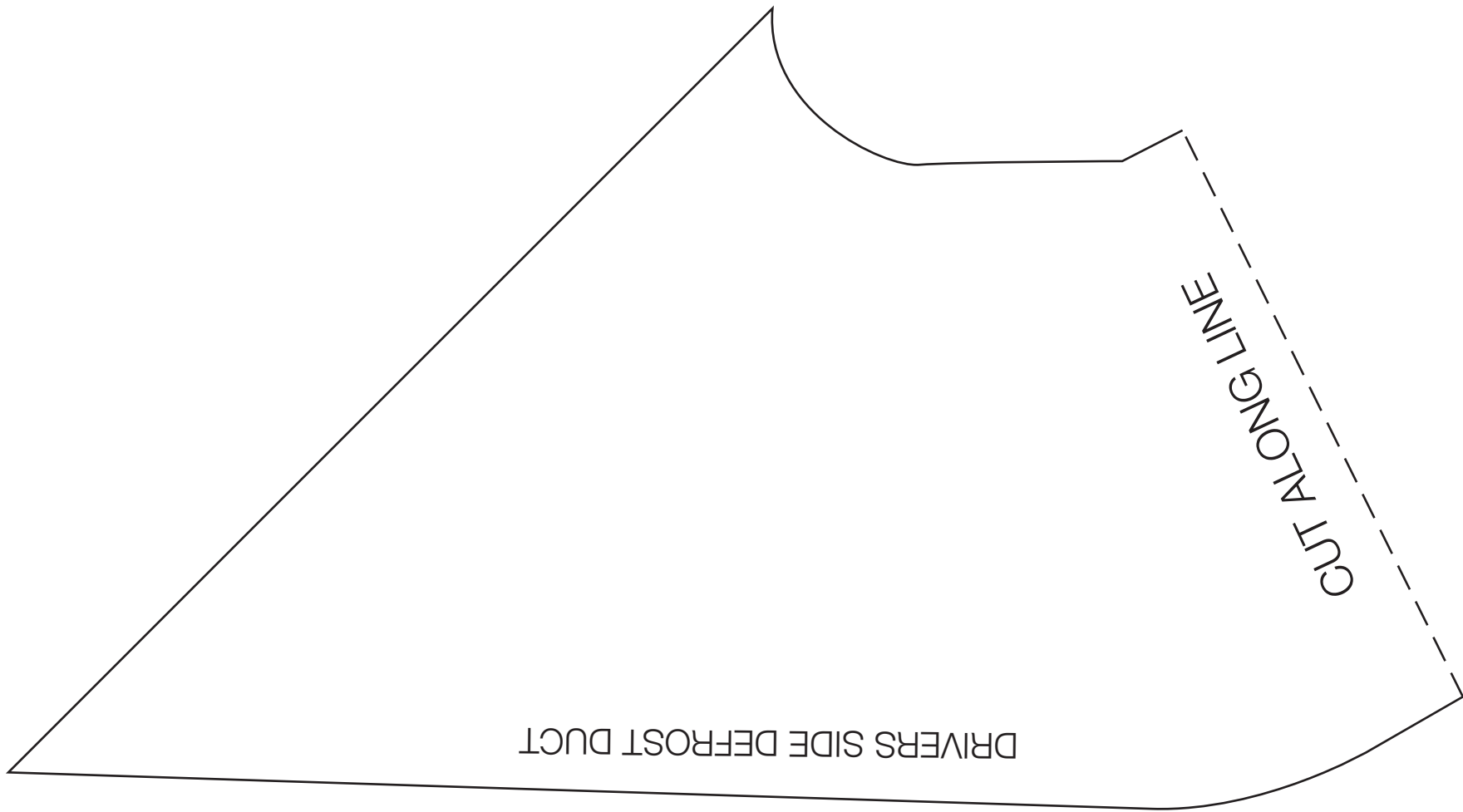

DRIVERS SIDE DEFFROST DUCT

CUT ALONG LINE

IF YOU PRINTED THIS MANUAL  
PLEASE READ THIS...  
Just as a cautionary step, please  
measure this box and make sure it  
is 1" x 1". Some copiers/printers  
may not print at 100% of actual size.







IF YOU PRINTED THIS MANUAL  
PLEASE READ THIS...

Just as a cautionary step, please  
measure this box and make sure it  
is 1" x 1". Some copiers/printers  
may not print at 100% of actual size.

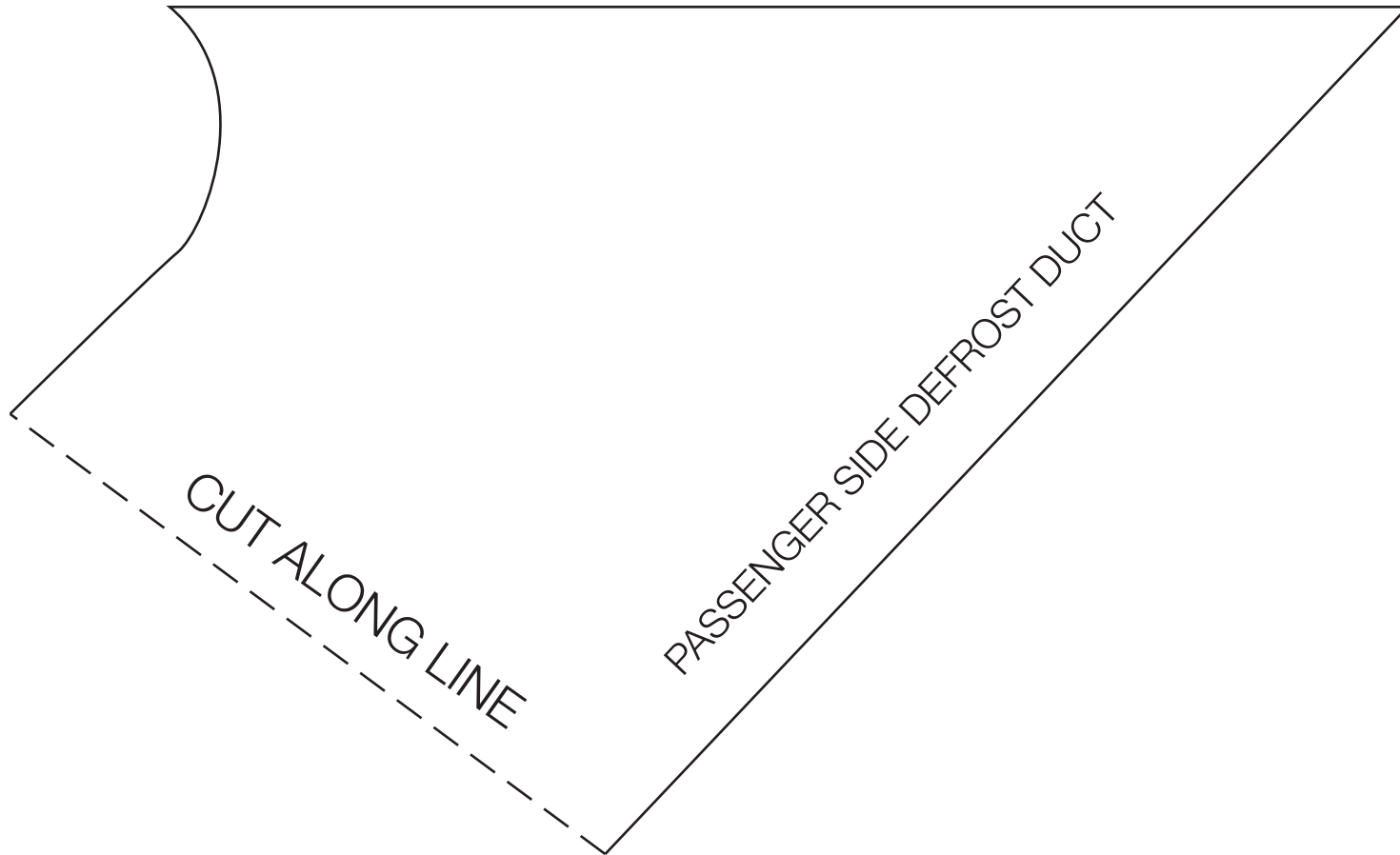



IF YOU PRINTED THIS MANUAL  
PLEASE READ THIS...  
Just as a cautionary step, please  
measure this box and make sure it  
is 1" x 1". Some copiers/printers  
may not print at 100% of actual size.

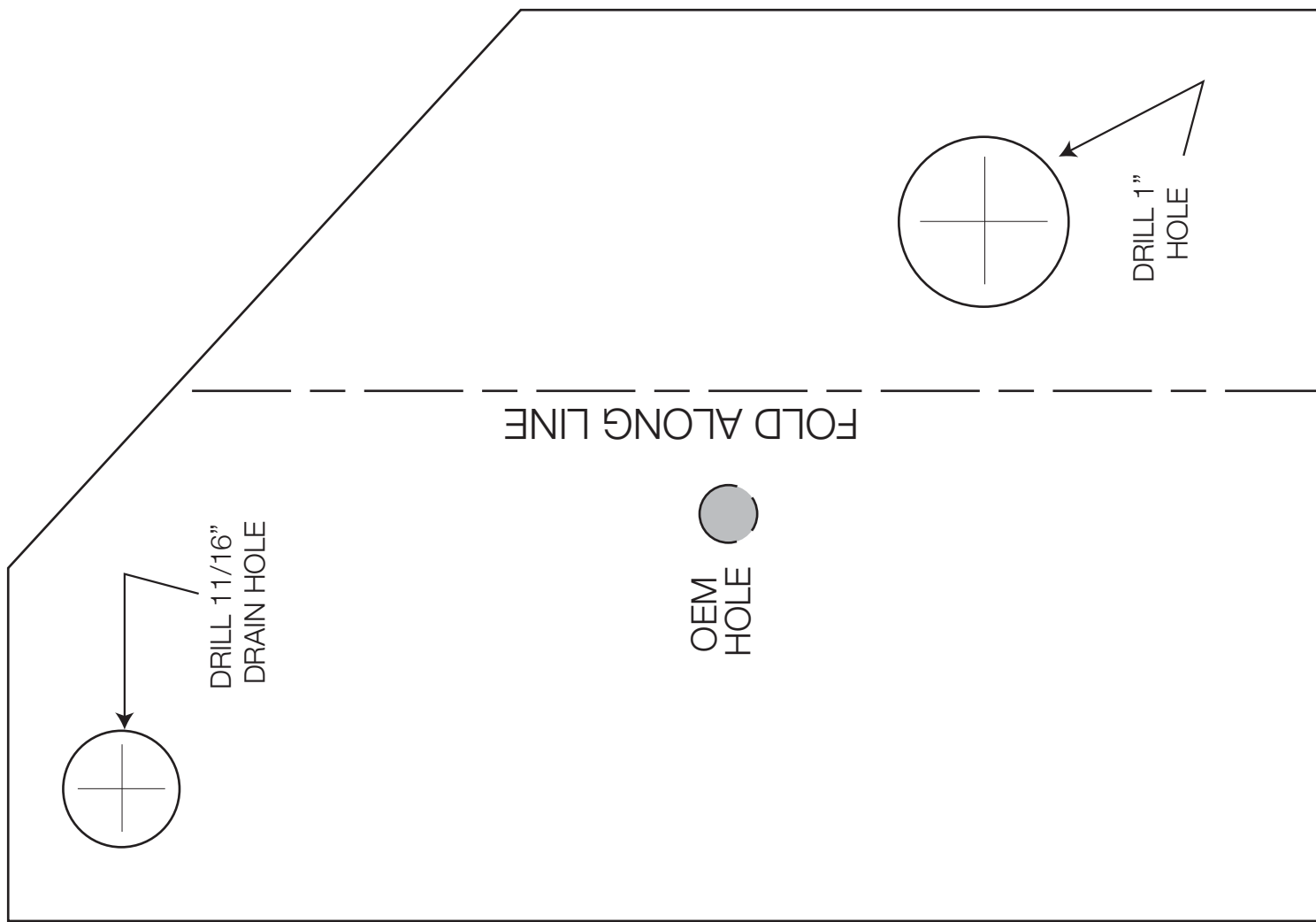



ALIGN WITH TOP EDGE  
OF RADIATOR COWL, 1978 CAMARO

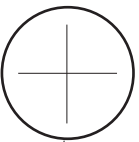

DRILL 1 1/16"  
DRAIN HOLE

FOLD ALONG LINE

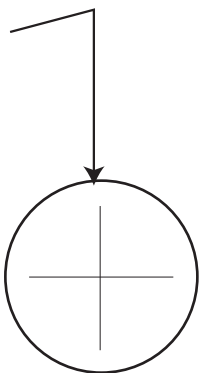

DRILL 1"  
HOLE

IF YOU PRINTED THIS MANUAL  
PLEASE READ THIS...  
Just as a cautionary step, please  
measure this box and make sure it  
is 1" x 1". Some copiers/printers  
may not print at 100% of actual size.



